

### Brass Globe Valves

PN20/300PSI/Class150

BSEN12288, Threaded Ends Comply to BSPT or ANSI 2.1

Hydraulic Pressure Test	
Body	3.0Mpa/30Bar
Seat	2.2Mpa/22Bar

Pressure Ratings	
0.9 Mpa at 180°C	
2.0 Mpa at -20°C-100°C	

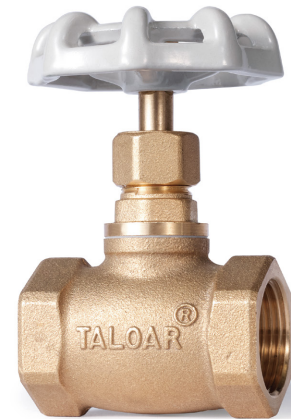

**G103**  
1/2" - 2"

#### Materials List

No	Part	Specification	BS EN	ASTM
1	Body	Brass	CW612N	C37700
2	Bonnet	Brass	CW612N	C37700
3	Disc	Brass	CW603N	C36000
4	Stem	Brass	CW603N	C36000
5	Sealing Ring	PTFE	PTFE	PTFE
6	Stem Packing	PTFE	PTFE	PTFE
7	Nut	Brass	CW603N	C36000
8	Handwheel	Cast iron	BSEN 1561	A126 CLASS B
9	Nameplate	Aluminum	--	B209 1100
10	Handwheel Nut	Stainless Steel	BS970 304S15	S30400

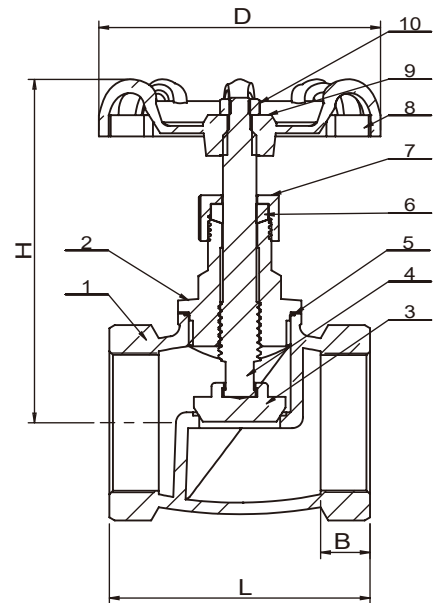

#### Dimensions-Weights

mm	15	20	25	32	40	50	
<b>In</b>	½	¾	1	1¼	1½	2	
<b>L</b>	49	55	63	74	82	94	
<b>H (closed)</b>	68	75	89	98	112	132	
<b>D</b>	54	60	72	80	90	100	
<b>B</b>	10	11	12	14	14	16	
<b>Weight</b>	<b>Lbs</b>	0.60	0.77	1.21	1.79	2.56	3.77
	<b>Kg</b>	0.27	0.35	0.55	0.81	1.16	1.71

\* **Freezing Weather Precaution:** Subsequent to testing a piping system, valves should be left in an open position to allow complete drainage.

Each TALOAR brass valve has been thoroughly cleaned and degreased and packed separately in the sealed polythene bag.