

Product Features

- Precise differential pressure control
- Small volume and light weight
- Large flow
- Reliable full hydraulic control
- Tight and reliable sealing performance in closing
- Built-in strainer, to prevent the guide piping system from being blocked

DR300 lightweight pressure differential relief valve is a fully automatic hydraulic control valve, designed to maintain pressure differential between two pipelines, to avoid the pressure differential of pipelines exceeding the range the system can hold due to other valves operation or demand change. The valve will open when the pressure differential increases and will automatically close when the differential pressure decreases.

If the optional check feature is selected, back pressure is generated, the return fluid will enter the air chamber to close the valve to prevent the fluid from back flow.

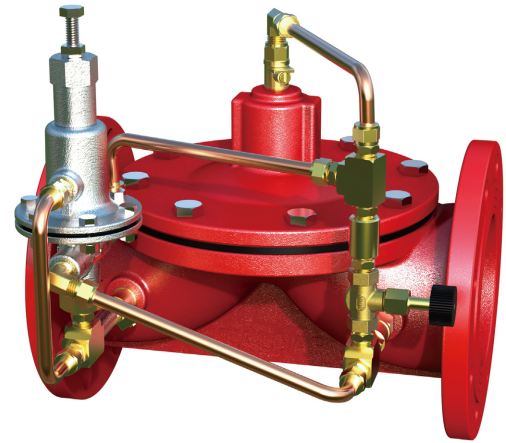

DR300

Material Specifications

Body/Bonnet: Ductile Iron/Stainless Steel
Disc & Stem: Stainless Steel
Piping: Bronze/Stainless Steel/Rubber Hose
Diaphragm: EPDM
Fasteners and Springs: Stainless Steel

Working Pressure Range

175PSI/235PSI
 10Bar/16Bar

Flange Standards

ANSI / BSEN / ISO / DIN

Temperature/Medium

0°C~100°C normal temperature water

Pressure Regulator Parameters

Pressure Regulating Range: 0.1~2.5 kgf/cm²,
 2~9 kgf/cm², 7~17 kgf/cm²

Pressure Regulator Material:
 Brass/Stainless Steel

Please Provide the Following Data When Ordering

Valve figure number/size/pressure grade/
 connecting end type/pressure regulating
 range/other optional accessories

* Note: In valve installation, it is strongly suggested that sufficient space should be left for easy maintenance in the future. A strainer shall be mounted in front of the valve to prevent foreign matters from blocking the valve.

List of Accessories

- ① Strainer
- ② Ball Valve
- ③ Needle Type Regulating Valve
- ④ Ball Valve
- ⑤ Differential Pressure Controller
- ⑥ Ball Valve
- ⑦ Body

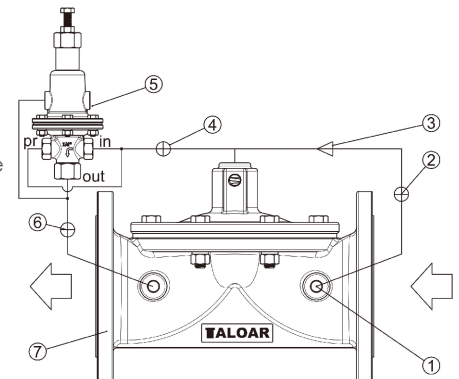

Piping Diagram

Typical Applications

The differential pressure relief valve can maintain pressure differential of the flow through the centrifugal pump. Disregard the upstream supply or downstream demand changes, the pressure differential can always be maintained within a certain range. The flow of the pump can be controlled by controlling the pressure differential between both ends of the centrifugal pump.

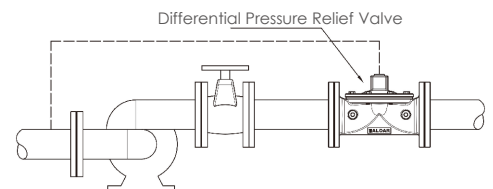

Installing DR300 differential pressure relief valve in the circulating water system, as shown in the diagram, can guarantee the pressure differential between the supply pipeline and the return pipeline, disregard the flow or supply pressure changes, the differential pressure between the two pipelines always remains constant.

