

Ductile Iron Gate Valves

PN16/235PSI/Class125

Non-Rising Stem, Resilient Wedge, Epoxy Coating
 Design to BS5150 and MSS SP-70
 Flange Dimension EN1092-2, ANSI B16.1 Class 125



FG970-EN

1 1/2" - 12"

Hydraulic Pressure Test	
Body	2.4Mpa/24Bar
Seat	1.76Mpa/17.6Bar

Sealing Performance	
EPDM	-20°C- 120°C
NBR	-10°C- 80°C

Materials List

No	Part	Specification	BS EN	ASTM
1	Body	Ductile Iron	BSEN 1563	A536 65-45-12
2	Disc	Ductile Iron Coated With EPDM	BSEN 1563	A536 65-45-12
3	Stem Nut	Brass	12164 CW603N	B16
4	Bonnet	Ductile Iron	BSEN 1563	A536 65-45-12
5	Stem	Stainless Steel	BS970 420S37	A276 42000
6	Gland Nut	Brass	12164 CW603N	B16
7	Handwheel	Ductile Iron	BSEN 1563	A536 65-45-12

* Fire protection water supply, drainage and water supply and non-corrosive gas

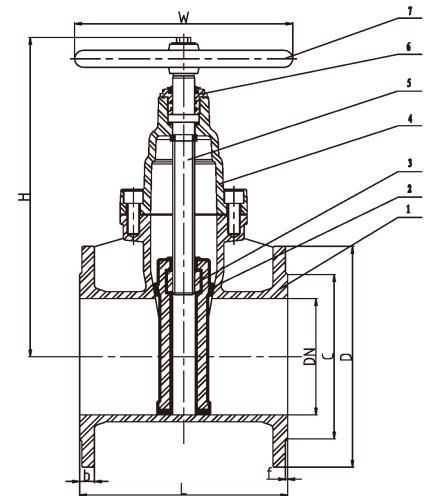
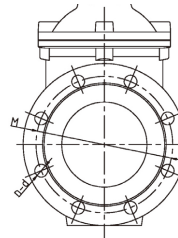

Dimensions-Weights

mm	40	50	65	80	100	125	150	200	250	300
In	1 1/2	2	2 1/2	3	4	5	6	8	10	12
L	165	178	190	203	229	254	267	292	330	356
H	240	250	265	300	350	410	450	550	650	710
C	88	102	122	138	158	188	212	268	320	378
D	150	165	185	200	220	250	285	340	405	460
M	110	125	145	160	180	210	240	295	355	410
b	19	19	19	19	19	19	19	20	22	24.5
n-d	4-19	4-19	4-19	8-19	8-19	8-19	8-23	12-23	12-28	12-28
Weight	Lbs	22	26	33	42	53	73	95	141	311
	Kg	10	12	15	19	24	33	43	64	141