

### Ductile Iron Gate Valves PN16/235PSI/Class125

Outside Screw and Yoke, Resilient Wedge, Epoxy Coating  
Design to BS5150 and MSS SP-70  
Flange Dimension EN1092-2, ANSI B16.1 Class 125

Hydraulic Pressure Test	
Body	2.4Mpa/24Bar
Seat	1.76Mpa/17.6Bar

Sealing Performance	
EPDM	-20°C- 120°C
NBR	-10°C- 80°C



**FG970-ER**  
2" - 24"

#### Materials List

No	Part	Specification	BS EN	ASTM
1	Body	Ductile Iron	BSEN 1563	A536 65-45-12
2	Disc	Ductile Iron Coated With EPDM	BSEN 1563	A536 65-45-12
3	Stem Nut	Brass	12164 CW603N	B16
4	Stem	Stainless Steel	BS970 420S37	A276 42000
5	Bonnet	Ductile Iron	BSEN 1563	A536 65-45-12
6	Packing	Graphite	Gr	Gr
7	Gland	Ductile Iron	BSEN 1563	A536 65-45-12
8	Support	Ductile Iron	BSEN 1563	A536 65-45-12
9	Stem Nut	Brass	12164 CW603N	B16
10	Handwheel	Ductile Iron	BSEN 1563	A536 65-45-12

\* Fire protection water supply, drainage and water supply and non-corrosive gas

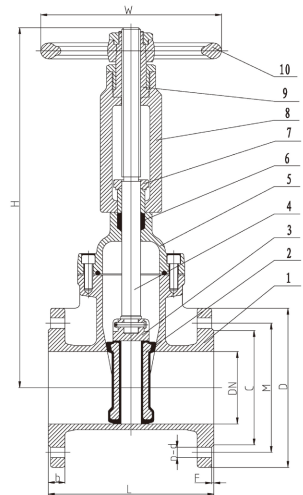

#### Dimensions-Weights

mm	50	65	80	100	125	150	200	250	300	350	400	450	500	600	
In	2	2 1/2	3	4	5	6	8	10	12	14	16	18	20	24	
L	178	190	203	229	254	267	292	330	356	381	406	432	457	508	
H	350	370	380	405	455	490	540	720	860	1185	1355	1570	1830	2150	
C	99	118	132	156	184	211	266	319	370	429	480	530	582	682	
D	165	185	200	220	250	285	340	405	460	520	580	640	715	840	
M	125	145	160	180	210	240	295	355	410	470	525	585	650	770	
b	19	19	19	19	19	19	20	22	24.5	26.5	28	30	32	36	
F	3	3	3	3	3	3	3	3	3	4	4	4	4	5	
W	200	200	250	280	280	350	400	450	540	600	600	600	750	750	
n-d	4-19	4-19	8-19	8-19	8-19	8-23	12-23	12-28	12-28	16-28	16-31	20-31	20-34	20-37	
Weight	Lbs	40	46	62	79	126	168	243	340	474	725	897	1191	1544	1985
	Kg	18	21	28	36	57	76	110	154	215	329	407	540	700	900