

Ductile Iron Gate Valves PN25/350PSI

Outside Screw and Yoke, Resilient Wedge, Epoxy Coating
Design to BS5150 and MSS SP-70
Flange Dimension EN1092-2, ANSI B16.1 Class 250

Hydraulic Pressure Test	
Body	3.75Mpa/37.5Bar
Seat	2.75Mpa/27.5Bar

Sealing Performance	
EPDM	-20°C- 120°C
NBR	-10°C- 80°C



FG975-ER
2" - 16"

Materials List

No	Part	Specification	BS EN	ASTM
1	Body	Ductile Iron	BSEN 1563	A536 65-45-12
2	Disc	Ductile Iron Coated With EPDM	BSEN 1563	A536 65-45-12
3	Stem Nut	Brass	12164 CW603N	B16
4	Stem	Stainless Steel	BS970 420S37	A276 42000
5	Bonnet	Ductile Iron	BSEN 1563	A536 65-45-12
6	Packing	Graphite	Gr	Gr
7	Gland	Ductile Iron	BSEN 1563	A536 65-45-12
8	Support	Ductile Iron	BSEN 1563	A536 65-45-12
9	Stem Nut	Brass	12164 CW603N	B16
10	Handwheel	Ductile Iron	BSEN 1563	A536 65-45-12

* Fire protection water supply, drainage and water supply and non-corrosive gas

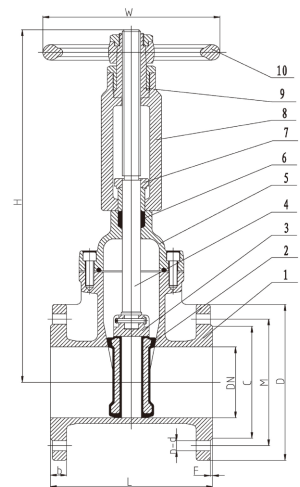

Dimensions-Weights

mm	50	65	80	100	125	150	200	250	300	350	400
In	2	2 1/2	3	4	5	6	8	10	12	14	16
L	178	190	203	229	254	267	292	330	356	381	406
H	350	370	380	405	455	490	540	720	860	1185	1355
C	102	122	138	162	188	218	278	335	395	450	505
D	165	185	200	235	270	300	360	425	485	555	620
M	125	145	160	190	220	250	310	370	410	470	550
b	21	21	21	21	21	21	22	24	26.5	28.5	30
F	3	3	3	3	3	3	3	3	3	4	4
W	200	200	250	280	280	350	400	450	540	600	600
n-d	4-19	4-19	8-19	8-19	8-19	8-23	12-23	12-28	12-28	16-28	16-31
Weight	Lbs	40	46	62	84	137	183	265	366	514	986
	Kg	18	21	28	38	62	83	120	166	233	447