

### Ductile Iron Globe Valves

PN16/235PSI/Class125

Outside Screw and Yoke, Bronze Seat

Design to BS5152 and MSS SP-85

Flange Dimension to EN1092-2, ANSI B16.1 Class 125

| Hydraulic Pressure Test |                 |
|-------------------------|-----------------|
| Body                    | 2.4Mpa/24Bar    |
| Seat                    | 1.76Mpa/17.6Bar |

| Pressure Ratings |                        |
|------------------|------------------------|
|                  | 1.0 Mpa at 180°C       |
|                  | 1.6 Mpa at -10°C-120°C |



**GL970-R**  
2" - 12"

#### Materials List

| No | Part              | Specification   | BS EN        | ASTM          |
|----|-------------------|-----------------|--------------|---------------|
| 1  | Body              | Ductile Iron    | BSEN 1563    | A536 65-45-12 |
| 2  | Seat Sealing Ring | Cast Bronze     | 1982 CC491K  | B62           |
| 3  | Disc Sealing Ring | Cast Bronze     | 1982 CC491K  | B62           |
| 4  | Disc              | Ductile Iron    | BSEN 1563    | A536 65-45-12 |
| 5  | Thrust Washer     | Stainless Steel | BSEN 10088-1 | AISI 304      |
| 6  | Nut               | Cast Brass      | 12164 CW603N | B16           |
| 7  | Stem              | Brass           | 12164 CW603N | B16           |
| 8  | Flange Gasket     | Graphite        | --           | --            |
| 9  | Bolt              | Steel           | BSEN 10087   | Steel A307    |
| 10 | Packing           | Graphite        | --           | --            |
| 11 | Bonnet            | Ductile Iron    | BSEN 1563    | A536 65-45-12 |
| 12 | Seal Gland        | Ductile Iron    | BSEN 1563    | A536 65-45-12 |
| 13 | Nut               | Steel           | BSEN 10087   | Steel A307    |
| 14 | Bolt              | Steel           | BSEN 10087   | Steel A307    |
| 15 | Stem Nut          | Cast Brass      | 12164 CW603N | B16           |
| 16 | Handwheel         | Cast Iron       | BSEN 1561    | A126 Class B  |
| 17 | Gasket            | Steel           | BSEN 10087   | Steel A307    |
| 18 | Nut               | Steel           | BSEN 10087   | Steel A307    |

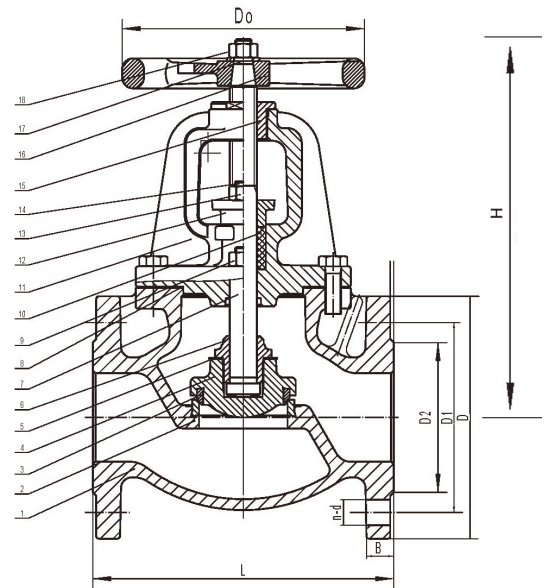

#### Dimensions-Weights

| mm     | 50   | 65    | 80   | 100  | 125  | 150  | 200   | 250   | 300   |     |
|--------|------|-------|------|------|------|------|-------|-------|-------|-----|
| In     | 2    | 2 1/2 | 3    | 4    | 5    | 6    | 8     | 10    | 12    |     |
| L      | 203  | 216   | 241  | 292  | 330  | 356  | 495   | 622   | 699   |     |
| H      | 315  | 345   | 387  | 490  | 576  | 680  | 808   | 1010  | 1080  |     |
| D      | 165  | 185   | 200  | 220  | 250  | 285  | 340   | 405   | 460   |     |
| D1     | 125  | 145   | 160  | 180  | 210  | 240  | 295   | 355   | 410   |     |
| D2     | 99   | 118   | 132  | 156  | 184  | 211  | 266   | 319   | 370   |     |
| D0     | 178  | 178   | 200  | 254  | 300  | 300  | 348   | 400   | 457   |     |
| B      | 20   | 20    | 22   | 24   | 26   | 26   | 30    | 32    | 32    |     |
| n-d    | 4-19 | 4-19  | 8-19 | 8-19 | 8-19 | 8-23 | 12-23 | 12-28 | 12-28 |     |
| Weight | Lbs  | 34    | 47   | 68   | 99   | 151  | 204   | 346   | 483   | 673 |
|        | Kg   | 16    | 22   | 31   | 45   | 68   | 93    | 157   | 219   | 305 |