

Ductile Iron Silent Check Valves

PN25/350PSI/Class 250

Globe Style Center-Oriented, Spring Actuated
Flange Dimension EN1092-2, ANSI B16.1



CF975-V
2" - 16"

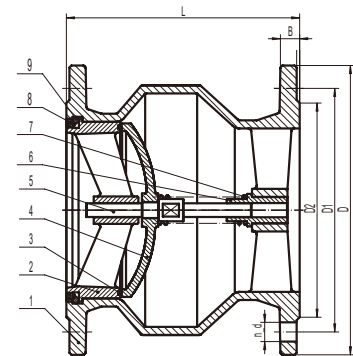

Hydraulic Pressure Test	
Body	3.75Mpa/37.5Bar
Seat	2.75Mpa/27.5Bar

Sealing Performance	
EPDM	-20°C- 120°C
NBR	-10°C- 80°C

Materials List

No	Part	Specification	BS EN	ASTM
1	Body	Ductile Iron	BSEN1563	A536 65-45-12
2	Seat Body	Ductile Iron	BSEN1563	A536 65-45-12
3	Seat	Rubber	EPDM	EPDM
4	Disc	Ductile Iron/Stainless Steel	BSEN1563	A536 65-45-12
5	Stem	Stainless Steel	BS970 304S15	S30400
6	Bushing	Brass	BS2874	B16 C36000
7	Spring	Stainless Steel	BS970 304S15	S30400
8	Screw	Stainless Steel	BS970 304S15	S30400
9	Ball	Stainless Steel	BS970 304S15	S30400

* Applicable to water supply system pipelines

* Stainless steel shell, valve core & stem assembly (Fig. CF370V)

Dimensions-Weights

mm		50	65	80	100	125	150	200	250	300	350	400
In		2	2½	3	4	5	6	8	10	12	14	16
L		133	140	152	185	216	230	259	362	393	400	448
D		165	185	200	235	270	300	360	425	485	555	620
D1		125	145	160	190	220	250	310	370	430	490	550
D2		99	118	132	156	184	211	274	330	389	448	503
B		19	19	19	19	19	20	22	24.5	27.5	30	32
n-d		4-19	8-19	8-19	8-23	8-28	8-28	12-28	12-31	16-31	16-34	16-37
Weight	Lbs	17	21	22	34	44	62	102	178	246	--	--
	Kg	8	9	10	15	20	28	46	81	112	--	--

Notes:

* Silent check valves should be installed at the outlets of pumps.

* Valves may be installed in any positions of horizontal or vertical pipelines, Not applicable to air compression pipelines.