

Fully Welded Ball Valves

PN16/235PSI/Class125

Reduced Bore, Worm Gear, Floating Ball
Design to EN488
Pressure Test to EN12266.1



WB3518-G
FXF

Materials List		
1	Body	A106-B, EN10217-2
2	Welded Pipe	A106-B, EN10217-2
3	Spring	AISI 304, EN10088-3
4	Fireproof Gasket	AISI 304
5	O-Ring	Viton
6	Seat Ring	PTFE 25%C
7	Ball	AISI 304, EN10088-3
8	Stem Guide	A106-B, EN10217-2
9	Stem	ASTM A420, EN10088-3
10	Thrust Washer	PPL
11	O-Ring	Viton
12	O-Ring	Viton
13	Gland	A106-B, EN10217-2
14	ISO Flange	ASTM A105
15	Screw	ASTM A193-B7
16	Spring Washer	ASTM 1566
17	Gearbox	ASTM A536

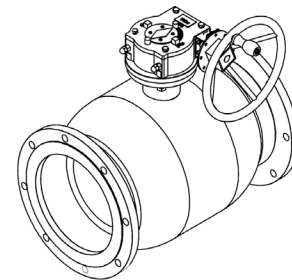
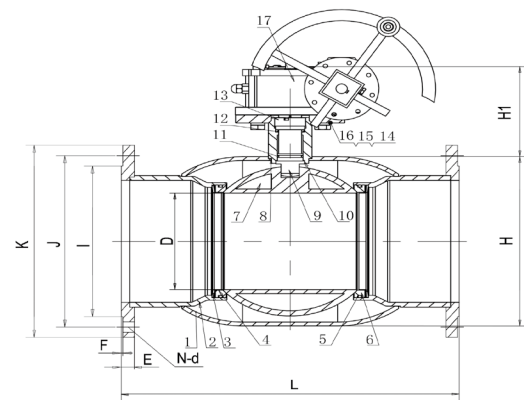

- * Operating temperature range: -30°C ~ +200°C .
- * For other materials and special requirements, please consult the factory or the local offices.

Dimensions/Weights													
In	D	H	L	H1	I	J	K	E	F	N-d	Kvs	Lbs	Kg
6	125	219	360	281	210	240	280	24	3	8-Φ23	1120	108	49
8	150	273	419	305	265	295	335	26	3	12-Φ23	1620	170	77
10	200	351	568	344	320	355	405	30	3	12-Φ25	3300	267	121
12	250	426	648	411	375	410	460	30	4	12-Φ25	4600	461	209

* Please consult the engineers for full-bore dimensions.