

### Fully Welded Ball Valves

PN25/400PSI/Class250

Reduced Bore, Worm Gear, Floating Ball  
Design to EN488  
Pressure Test to EN12266.1



WB3522-G  
SXS

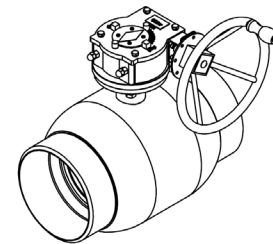
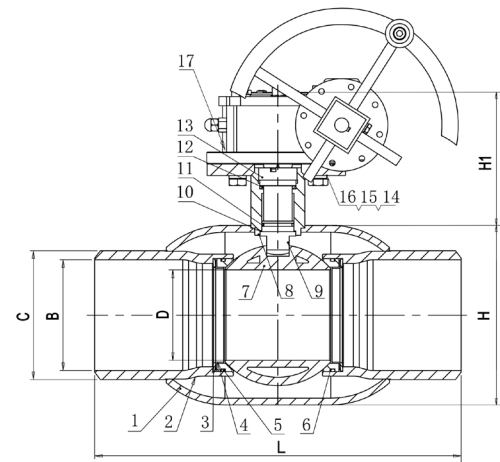

Materials List		
1	Body	A106-B, EN10217-2
2	Welded Pipe	A106-B, EN10217-2
3	Spring	AISI 304, EN10088-3
4	Fireproof Gasket	AISI 304
5	O-Ring	Viton
6	Seat Ring	PTFE 25%C
7	Ball	AISI 304, EN10088-3
8	Stem Guide	A106-B, EN10217-2
9	Stem	ASTM A420, EN10088-3
10	Thrust Washer	PPL
11	O-Ring	Viton
12	O-Ring	Viton
13	Gland	A106-B, EN10217-2
14	ISO Flange	ASTM A105
15	Screw	ASTM A193-B7
16	Spring Washer	ASTM 1566
17	Gearbox	ASTM A536

\* Operating temperature range: -30°C ~ +200°C .  
\* For other materials and special requirements, please consult the factory or the local offices.

Dimensions/Weights									
In	D	B	C	H	L	H1	Kvs	Lbs	Kg
2½	50	64	76	102	300	164	185	12.6	5.7
3	65	77	89	127	300	177	295	19.6	8.9
4	80	96	108	152	325	233	460	27.6	12.5
6	125	147	159	219	350	281	1120	75	34
8	150	199	219	273	400	305	1620	119	54
10	200	253	273	351	560	353	3300	194	88
12	250	301	325	426	635	417	4600	364	165

\* Please consult the engineers for full-bore dimensions.