

Fully Welded Ball Valves

PN25/400PSI/Class250

Reduced Bore, Leverage, Floating Ball
Design to EN488
Pressure Test to EN12266.1

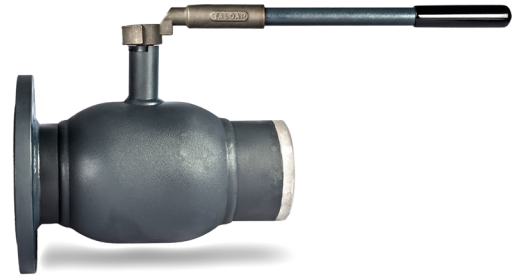

WB3523-P
FXS

Materials List		
1	Body	A106-B, EN10217-2
2	Welded Pipe	A106-B, EN10217-2
3	Spring	AISI 304, EN10088-3
4	Fireproof Gasket	AISI 304
5	O-Ring	Viton
6	Seat Ring	PTFE 25%C
7	Ball	AISI 304, EN10088-3
8	Stem Guide	A106-B, EN10217-2
9	Stem	ASTM A420, EN10088-3
10	Thrust Washer	PPL
11	O-Ring	Viton
12	O-Ring	Viton
13	Packing	Graphite
14	Gland	A106-B, EN10217-2
15	Pin	ASTM 1566
16	Handle	ASTM A216

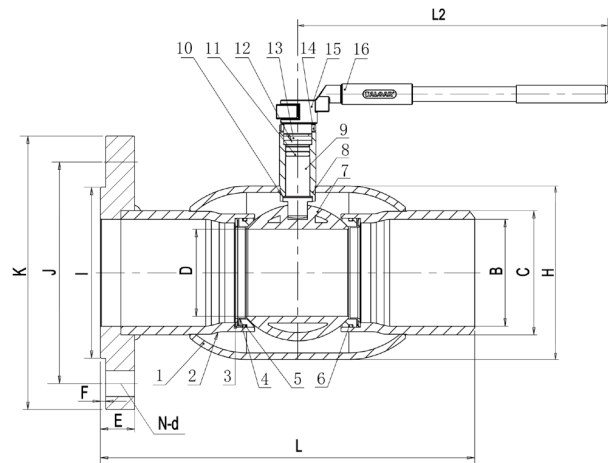

* Operating temperature range: -30°C ~ +200°C .
* For other materials and special requirements, please consult the factory or the local offices.

Dimensions/Weights															
In	D	B	C	H	I	J	K	E	F	N-d	L	L2	Kvs	Lbs	Kg
2 ½	50	64	76	102	120	145	180	22	3	8-Φ18	285	420	185	20.7	9.4
3	65	77	89	127	135	160	195	22	3	8-Φ18	290	420	295	30.2	13.7
4	80	96	108	152	160	190	230	24	3	8-Φ23	312.5	420	460	41.9	19.0
5	100	121	133	180	188	220	270	28	3	8-Φ25	337.5	420	730	60.0	27.2
6	125	147	159	219	218	250	300	30	3	8-Φ25	355	420	1120	101.4	46.0

* Please consult the engineers for full-bore dimensions.