

### Fully Welded Ball Valves

PN25/400PSI/Class250

Reduced Bore, Worm Gear, Floating Ball  
Design to EN488  
Pressure Test to EN12266.1



WB3528-G  
FXF

Materials List		
1	Body	A106-B, EN10217-2
2	Welded Pipe	A106-B, EN10217-2
3	Spring	AISI 304, EN10088-3
4	Fireproof Gasket	AISI 304
5	O-Ring	Viton
6	Seat Ring	PTFE 25%C
7	Ball	AISI 304, EN10088-3
8	Stem Guide	A106-B, EN10217-2
9	Stem	ASTM A420, EN10088-3
10	Thrust Washer	PPL
11	O-Ring	Viton
12	O-Ring	Viton
13	Gland	A106-B, EN10217-2
14	ISO Flange	ASTM A105
15	Screw	ASTM A193-B7
16	Spring Washer	ASTM 1566
17	Gearbox	ASTM A536

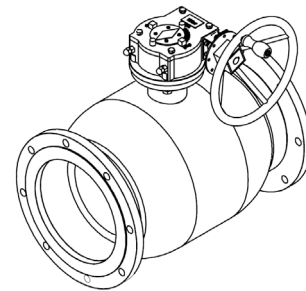
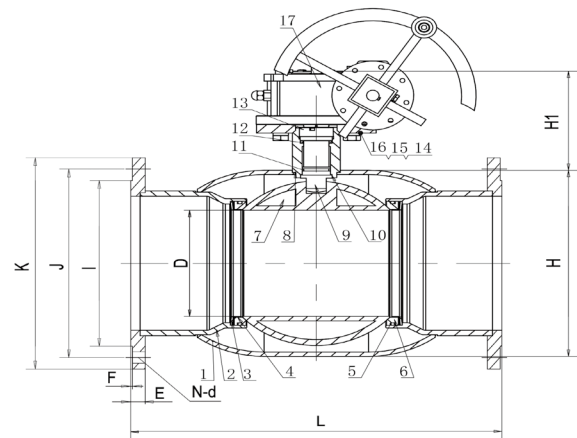

\* Operating temperature range: -30°C ~ +200°C .  
\* For other materials and special requirements, please consult the factory or the local offices.

Dimensions/Weights													
In	D	H	L	H1	I	J	K	E	F	N-d	Kvs	Lbs	Kg
6	125	219	360	281	218	250	300	30	3	8-Φ25	1120	126	57
8	150	273	419	305	278	310	360	34	3	12-Φ25	1620	194	88
10	200	351	568	353	332	370	425	36	3	12-Φ30	3300	300	136
12	250	426	648	417	390	430	485	40	4	16-Φ30	4600	503	228

\* Please consult the engineers for full-bore dimensions.