

### Fully Welded Ball Valves

PN25/400PSI/Class250

Reduced Bore, Leverage, Floating Ball  
Design to EN488  
Pressure Test to EN12266.1



WB3528-P  
FXF

Materials List		
1	Body	A106-B, EN10217-2
2	Welded Pipe	A106-B, EN10217-2
3	Spring	AISI 304, EN10088-3
4	Fireproof Gasket	AISI 304
5	O-Ring	Viton
6	Seat Ring	PTFE 25%C
7	Ball	AISI 304, EN10088-3
8	Stem Guide	A106-B, EN10217-2
9	Stem	ASTM A420, EN10088-3
10	Thrust Washer	PPL
11	O-Ring	Viton
12	O-Ring	Viton
13	Packing	Graphite
14	Gland	A106-B, EN10217-2
15	Pin	ASTM 1566
16	Handle	ASTM A216

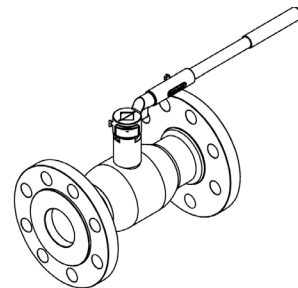
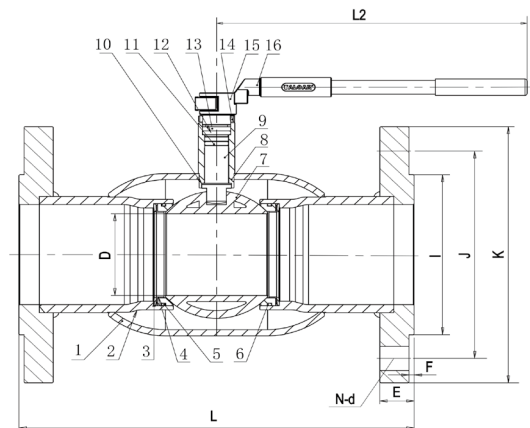

\* Operating temperature range: -30°C ~ +200°C .  
\* For other materials and special requirements, please consult the factory or the local offices.

Dimensions/Weights												
In	D	I	J	K	E	F	N-d	L	L2	Kvs	Lbs	Kg
2 ½	50	120	145	180	22	3	8-Φ18	270	420	185	28.9	13.1
3	65	135	160	195	22	3	8-Φ18	280	420	295	40.8	18.5
4	80	160	190	230	24	3	8-Φ18	300	420	460	56.2	25.5
5	100	188	220	270	28	3	8-Φ18	350	420	730	79.6	36.1
6	125	218	250	300	30	3	8-Φ23	360	420	1120	125.7	57

\* Please consult the engineers for full-bore dimensions.