

Triple Eccentric Butterfly Valves Metal Seal, Lug

1500PSI / Class600
 Design to ASME B16.34/API609
 Dimensions to ASME B16.5/B16.1/EN1092
 Pressure Test to API598/ISO5208
 Temperature Range: -50°C~650°C/-58°F~1200°F



HP5203-0

Materials List		
1	Lower End Cap	ASTM A105
2	Lower Shaft Sleeve	ASTM A276 304
3	Body	ASTM A216 WCB ASTM A351 CF8/CF8M
4	Lower Stem	ASTM A276 431 ASTM A564 630-17-4PH
5	Cylindrical Pin	ASTM A182 F304
6	Disc	ASTM A216 WCB ASTM A351 CF8/CF8M
7	Upper Stem	ASTM A276 431 ASTM A564 630-17-4PH
8	Upper Shaft Sleeve	ASTM A276 304
9	Packing	Graphite
10	Packing Gland	ASTM A216 WCB
11	Support	Carbon Steel
12	Seat	SS316, Stellite, Inconel
13	Seal Ring	SS316 + Graphite
14	Press Plate	ASTM A105 ASTM A182 F316
15	Hexagon Socket Head Bolt	ASTM A193 B7
16	Support Bolt	ASTM A193 B7
17	Spring Washer	ASTM A29 1566
18	Nut	ASTM A194 2H
19	Gland Bolt	ASTM A193 B7
20	Spring Washer	ASTM A29 1566
21	Nut	ASTM A194 2H

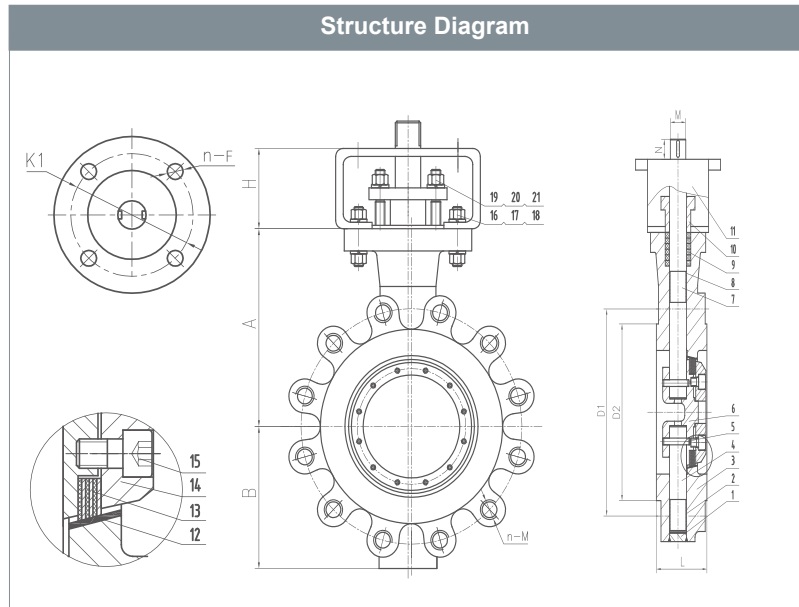

* For other materials and special requirements, consult factory or local offices.

Dimensions(600LB)											
In	L	D1	D2	n-M	H	A	B	M	N	K1	n-F
6	78	292.1	215.9	12-M27	90	250	200	32	50	125	4-14
8	102	349.2	269.9	12-M30	120	270	220	42	55	140	4-18
10	117	431.8	323.8	16-M33	120	320	270	52	60	165	4-22
12	140	489	381	20-M33	120	350	290	58	70	165	4-22
14	155	527	412.8	20-M36	150	440	340	68	80	200	8-18
16	178	603.2	469.9	20-M39	150	480	380	68	80	200	8-18
18	200	654	533.4	20-M42	150	530	440	76	90	254	8-18
20	216	723.9	584.2	24-M42	170	560	460	82	100	298	8-22
24	232	838.2	692.2	24-M48	200	600	500	96	120	356	8-33

* For EN and other standards dimensions, consult factory.