

Stainless Steel Butterfly Valves

PN16/235PSI/Class125

Wafer Style
Design to EN953 and MSS SP-67
Flange Dimension to EN1092-2, ANSI B16.1 Class 125



HB350-L/G/O
2" - 12"

Sealing Performance	
EPDM	-20°C- 120°C
NBR	-10°C- 80°C
VITON	-20°C- 150°C

Hydraulic Pressure Test	
Body	2.4Mpa/24Bar
Seat	1.76Mpa/17.6Bar

Materials List

No	Part	Specification	BS EN	ASTM
1	Body	Stainless Steel	BS970 316 BS970 304	CF8M CF8
2	Disc	Stainless Steel	BS970 316 BS970 304	CF8M CF8
3	Seat	EPDM NBR VITON	EPDM NBR VITON	EPDM NBR VITON
4	Shaft	Stainless Steel	BSEN 10088-1	A582 420
5	Bushing	VITON	PTFE	PTFE
6	Sealing Ring	Rubber	NBR	NBR

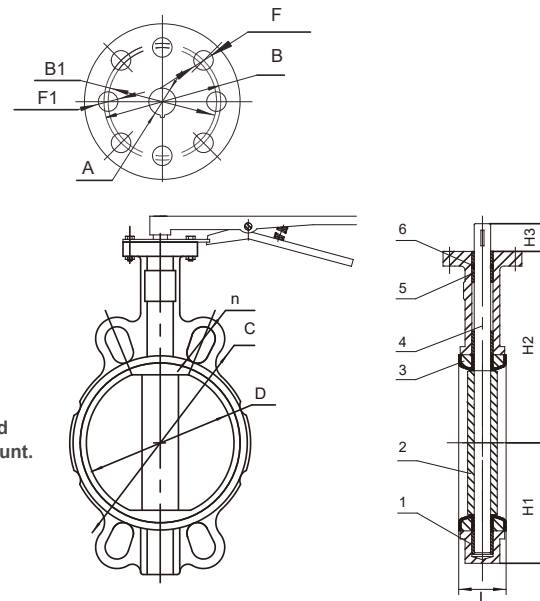

* Suffix - L for operation by lever, - G for operation by worm gear, - O for polished rod
 * An electric or pneumatic actuator may be mounted to match an ISO5211-based mount.
 Please refer to the TALOAR Butterfly Valve Torque Table in Page 46.

Dimensions

mm	50	65	80	100	125	150	200	250	300	
In	2	2½	3	4	5	6	8	10	20	
L	46	49	49	55	58	59	64	71.5	81	
H1	68	74	92	107	121	136	171	200	239	
H2	122	133	143	164	185	196	225	267	311	
H3	30	30	30	30	30	30	36	36	36	
D	52.7	64.4	78.8	104	123.3	156	202.3	250.3	301.3	
EN	C	125	145	160	180	210	240	295	355	410
	n-d	4-18	4-18	8-18	8-18	8-18	8-23	12-23	12-27	12-27
AN	C	120.5	139.5	152.5	190.5	216	241.5	298.5	362	432
	n-d	4-19	4-19	4-19	8-19	8-22	8-22	8-22	12-25	12-25
B	57.15	57.15	57.15	70	70	70	88.9	88.9	107.95	
B1	50	50	50	70	70	70	88.9	88.9	107.95	
F	7	7	7	9	9	9	14	14	14	
F1	7	7	7	9	9	9	14	14	14	

Note: Steam services are not recommended. For valves over 6" , operation by the worm gear is suggested.