

HIGH PERFORMANCE BUTTERFLY VALVES

Triple Eccentric Butterfly Valves

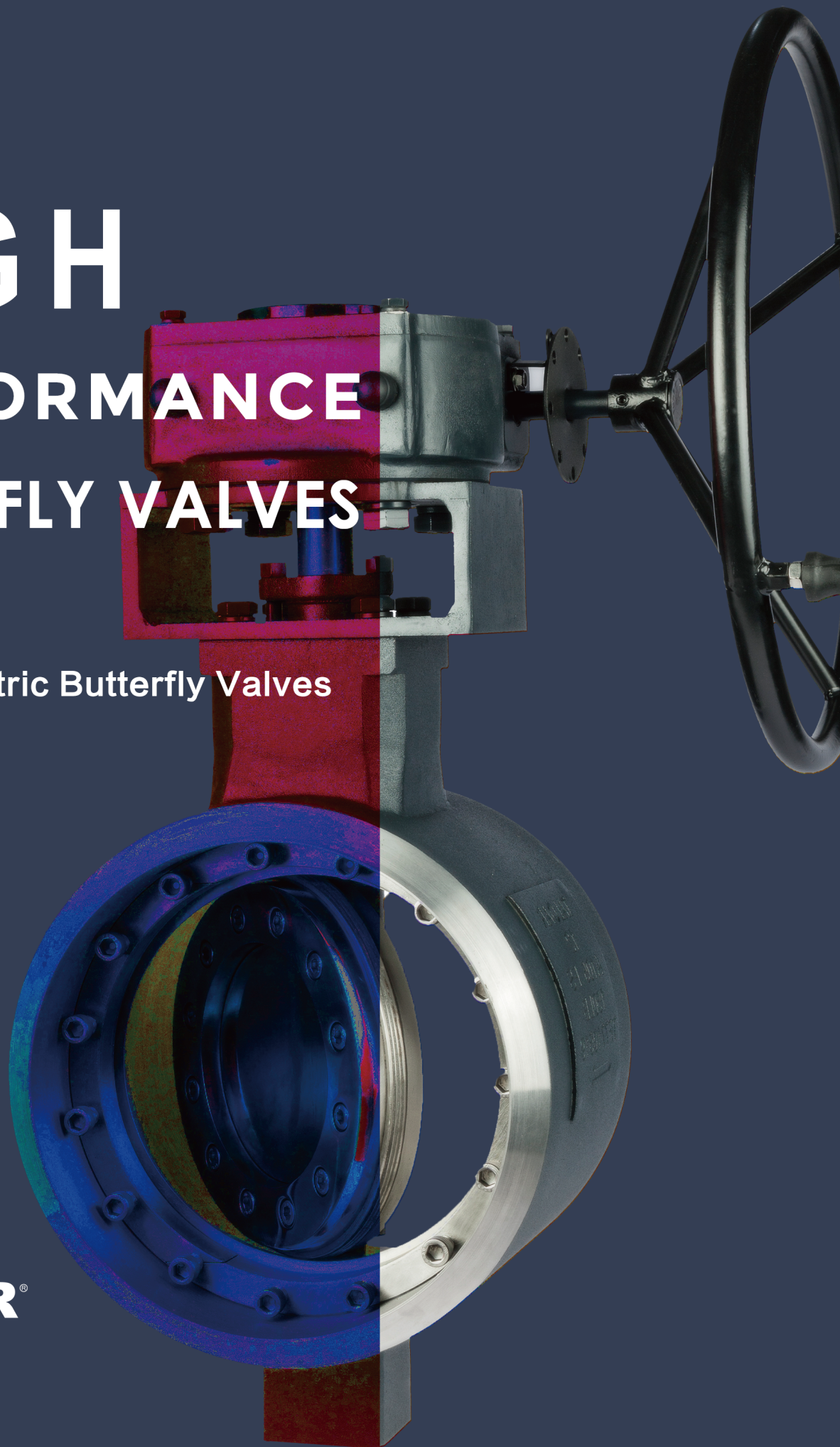

TALoar[®]

Taloor Changzhou
FLUIDSYSTEMS, 2023

TALOAR 

LEADING OVERALL ENERGY HEATING SOLUTION

Taloar is a world-leading supplier of flow control products and services, providing a diverse range of fluid control products that has wide applicability to commerce, water service and industry.

The solutions provided by Taloar constitute an important part of the leading plant asset management strategies.



Taloor

combines the latest mechanical technologies and advanced automation systems in its production to ensure our products consistently maintain excellent quality.

Taloor

always cares and concerns for our users, which is not just a slogan, but a fundamental aspect ingrained in every decision and action taken by the company.

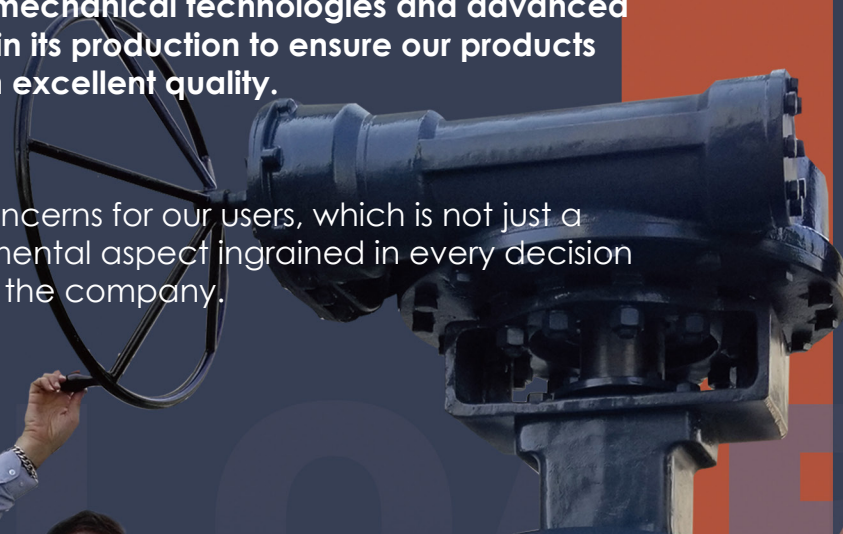

Taloor's quality policy is of top priority. We not only serve as a leader in flow products, but also as a recognized model in technical services.

Taloor will continue to update our products and services, correcting any deviations where necessary. We will keep up with the times and raise our quality standards to new levels, striving for perfection in every product we sell, continuously making progress, understanding our customers' concern, evaluating their needs, and assessing their satisfaction.





TALOAR high-performance triple eccentric butterfly valves

are designed for sectional energy heating, power generation and crude oil transmission pipeline systems as well as for pipeline systems under harsh medium working conditions. TALOAR products, manual or automatic control, demonstrate excellent product performance. Besides, TALOAR provides on-site services and one-stop solutions for our clients.

PRODUCT DESCRIPTION

- The body is made of high-quality carbon steel, forged steel or stainless steel.
- Multi-layer assembled valve seat sealing material ensures two-way sealing and zero leakage. It is resistant to medium scouring and wear, and can be maintained and replaced on site. It can offer stainless steel or Stellite hard alloy for higher requirements.
- The stainless-steel disc is designed with full bore to ensure medium circulation and provide maximum flow. The valve shaft is anti-blow-out structure design made of high-strength, anti-corrosion 17-4PH stainless steel.
- The stainless-steel shaft sleeve is specially hardened treated, resistant to high temperature and corrosion, perfectly fit to the valve shaft.
- On site adjustable graphite packing and carbon fiber gasket offer dual seal to ensures seal tightness, longer service life.

Design to ASME B16.34, API 609, EN488

Dimensions to ASME B16.5, B16.1, ISO 5752, EN1092

Pressure test to API 598, ISO5208, EN12266-1

Top flange to ISO5211

End type : Wafer, Lug, Flanged, Or butt-welded

Temperature range : -50°C~650°C / -58°F~1200°F

Pressure range : 150 LB, 300 LB, 600 LB, 900 LB

Size range : 2"- 64"

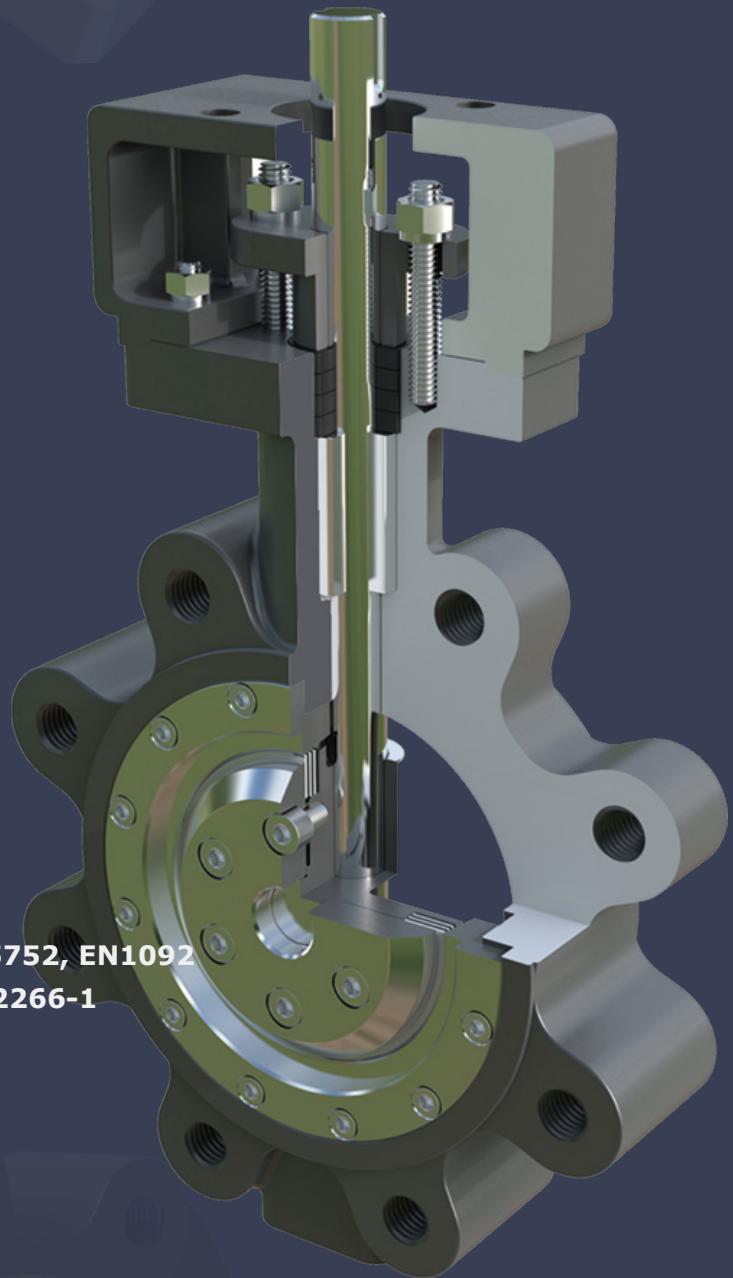

DESIGN PRINCIPLE OF TRIPLE ECCENTRIC BUTTERFLY VALVES

TALOAR' s design provides ever-stable quality to fully meet the valve requirements even under harsh working conditions.

The triple eccentric butterfly valve is designed with angular eccentricity based on double eccentricity. In that way, the body can be separated quickly from the valve seat while the valve is operated. There is no friction between the inclined cone surface of the valve seat and the sealing surface of the body while the valve is closing. The operation torque is low to ensure two-way

Has its metal sealing material installed on the disc. The multi-layer combined seal, made of high-quality stainless steel + graphite + carbon fiber + PTFE + other materials, can effectively prevent the medium from scouring and wearing the valve seat in long-term service. Under the special medium working conditions, the integral all-metal or higher standard sealing materials can be selected. The valve seat annular sealing materials, assembled on the disc and replaceable, can be maintained in the pipelines on site.

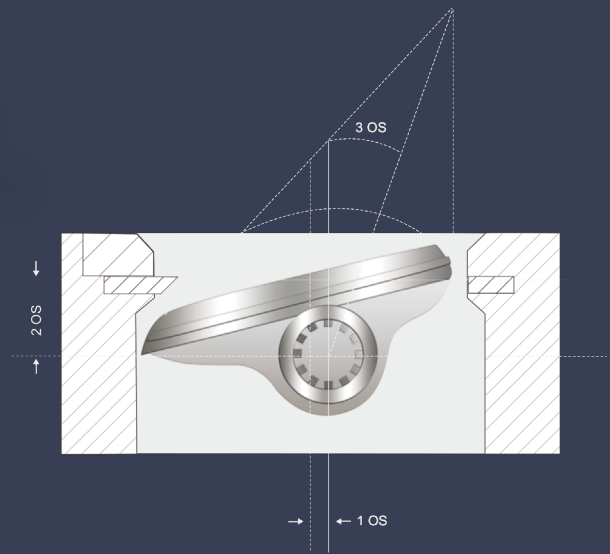

The center line of the valve shaft deviates from both the center of the disc and the center of the body, the center line of the body forms certain angle with the inclined cone surface of the valve seat to ensure that there is no friction between the disc and the sealing surface of the valve seat while the valve is opened or closed, to achieve uniform sealing.

Figure Number System

Body	End	Disc	Seat	Pressure
5—Cast steel	0—Flanged type	0—Cast steel +Graphite	3—Stellite	1—150LB
6—Stainless steel304	1—Wafer type	1—Stainless steel+Graphite	5—Stainless steel 316	2—300LB
7—Stainless steel316	2—Lug type	3—Stainless steel 304	7—Stellited	5—300LB
9—Nickel aluminum bronze	3—Welded type	5—Stainless steel 316	9—Inconel	0—600LB
0—Low-temperature steel				

Contents Page



Triple Eccentric Butterfly Valves Metal Seal, Flanged

300PSI / Class150
 Design to ASME B16.34/API609
 Dimensions to ASME B16.5/B16.1/EN1092
 Pressure Test to API598/ISO5208
 Temperature Range: -50°C~650°C/-58°F~1200°F

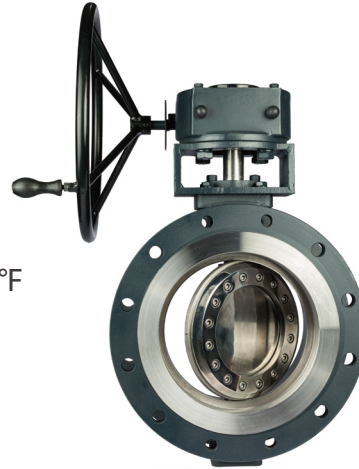

HP5003-1

Materials List		
1	Lower End Cap	ASTM A105
2	Lower Shaft Sleeve	ASTM A276 304
3	Body	ASTM A216 WCB ASTM A351 CF8/CF8M
4	Lower Stem	ASTM A276 431 ASTM A564 630-17-4PH
5	Cylindrical Pin	ASTM A182 F304
6	Disc	ASTM A216 WCB ASTM A351 CF8/CF8M
7	Upper Stem	ASTM A276 431 ASTM A564 630-17-4PH
8	Upper Shaft Sleeve	ASTM A276 304
9	Packing	Graphite
10	Packing Gland	ASTM A216 WCB
11	Support	Carbon Steel
12	Seat	SS316, Stellite, Inconel
13	Seal Ring	SS316 + Graphite
14	Press Plate	ASTM A105 ASTM A182 F316
15	Hexagon Socket Head Bolt	ASTM A193 B7
16	Support Bolt	ASTM A193 B7
17	Spring Washer	ASTM A29 1566
18	Nut	ASTM A194 2H
19	Gland Bolt	ASTM A193 B7
20	Spring Washer	ASTM A29 1566
21	Nut	ASTM A194 2H

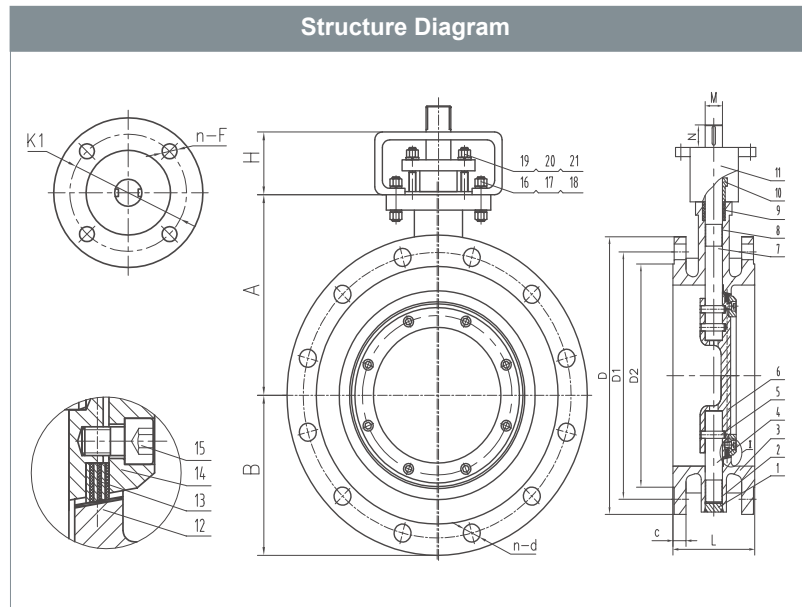

* For other materials and special requirements, consult factory or local offices.

Dimensions(150LB)													
In	L	D	D1	D2	C	n-d	H	A	B	M	N	K1	n-F
3	114	190	152.4	127	24.3	4-18	65	150	95	16	35	70	4-10
4	127	230	190.5	157.2	24.3	8-18	65	156	102	20	35	70	4-10
5	140	255	215.9	185.7	24.3	8-22	65	178	117	22	35	70	4-10
6	140	280	241.3	215.9	25.9	8-22	65	190	134	26	45	102	4-12
8	152	345	298.5	269.9	29	8-22	90	220	170	32	55	125	4-14
10	165	405	360	323.8	30.6	12-26	90	258	207	36	60	125	4-14
12	178	485	431.8	381	32.2	12-26	90	290	230	38	65	140	4-18
14	190	535	476.3	412.8	35.4	12-30	120	330	270	46	70	140	4-18
16	216	595	539.8	469.9	37	16-30	120	378	340	52	80	165	4-22
18	222	635	577.9	533.4	40.1	16-33	120	390	355	58	90	200	8-18
20	229	700	635	584.2	43.3	20-33	120	410	370	68	100	254	8-18
24	267	815	749.3	692.2	48.1	20-36	150	480	430	76	120	298	8-22

* For EN and other standards dimensions, consult factory.

Triple Eccentric Butterfly Valves Metal Seal, Flanged

300PSI / Class150
 Design to ASME B16.34/API609
 Dimensions to ASME B16.5/B16.1/EN1092
 Pressure Test to API598/ISO5208
 Temperature Range: -50°C~650°C/-58°F~1200°F

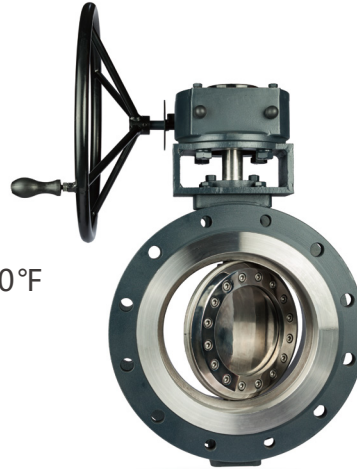

HP5003-1

Materials List		
1	Lower End Cap	ASTM A105
2	Lower Shaft Sleeve	ASTM A276 304
3	Body	ASTM A216 WCB ASTM A351 CF8/CF8M
4	Lower Stem	ASTM A276 431 ASTM A564 630-17-4PH
5	Cylindrical Pin	ASTM A182 F304
6	Disc	ASTM A216 WCB ASTM A351 CF8/CF8M
7	Upper Stem	ASTM A276 431 ASTM A564 630-17-4PH
8	Upper Shaft Sleeve	ASTM A276 304
9	Packing	Graphite
10	Packing Gland	ASTM A216 WCB
11	Support	Carbon Steel
12	Seat	SS316, Stellite, Inconel
13	Seal Ring	SS316 + Graphite
14	Press Plate	ASTM A105 ASTM A182 F316
15	Hexagon Socket Head Bolt	ASTM A193 B7
16	Support Bolt	ASTM A193 B7
17	Spring Washer	ASTM A29 1566
18	Nut	ASTM A194 2H
19	Gland Bolt	ASTM A193 B7
20	Spring Washer	ASTM A29 1566
21	Nut	ASTM A194 2H

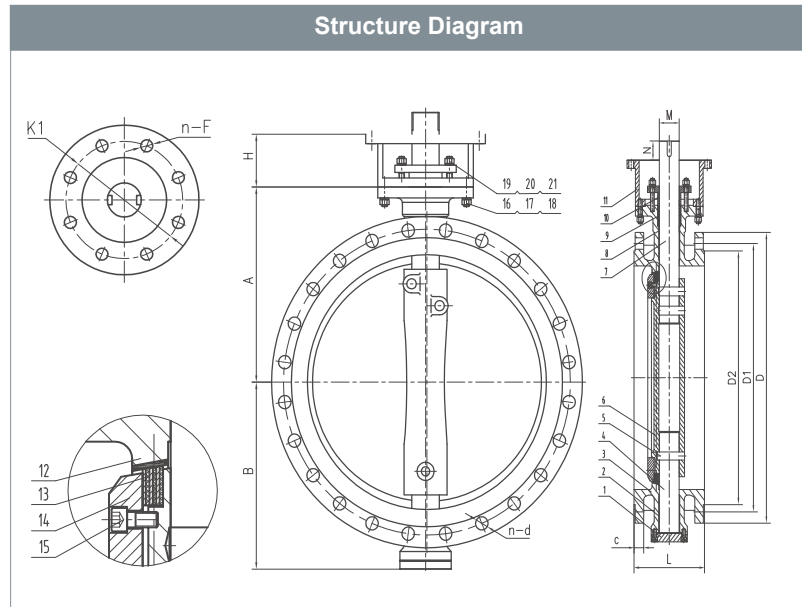

*For other materials and special requirements, consult factory or local offices.

Dimensions(150LB)													
ln	L	D	D1	D2	C	n-d	H	A	B	M	N	K1	n-F
28	292	835	795.3	762	45	40-22	150	530	490	82	130	356	8-33
32	318	940	900.1	864	46.6	48-22	150	615	555	96	140	356	8-33
36	330	1055	1009.6	972	50.9	44-30	170	675	595	106	150	356	8-33
40	410	1175	1120.8	1080	56.1	44-30	170	980	750	116	160	406	8-39
48	470	1390	1335.1	1289	65.6	44-33	200	1100	870	136	160	483	12-39
56	530	1495	1436.7	1391	70.4	52-33	200	1180	930	156	170	483	12-39

* For EN and other standards dimensions, consult factory.

Triple Eccentric Butterfly Valves Metal Seal, Flanged

600PSI / Class300

Design to ASME B16.34/API609

Dimensions to ASME B16.5/B16.1/EN1092

Pressure Test to API598/ISO5208

Temperature Range: -50°C~650°C/-58°F~1200°F



HP5003-2

Materials List		
1	Lower End Cap	ASTM A105
2	Lower Shaft Sleeve	ASTM A276 304
3	Body	ASTM A216 WCB ASTM A351 CF8/CF8M
4	Lower Stem	ASTM A276 431 ASTM A564 630-17-4PH
5	Cylindrical Pin	ASTM A182 F304
6	Disc	ASTM A216 WCB ASTM A351 CF8/CF8M
7	Upper Stem	ASTM A276 431 ASTM A564 630-17-4PH
8	Upper Shaft Sleeve	ASTM A276 304
9	Packing	Graphite
10	Packing Gland	ASTM A216 WCB
11	Support	Carbon Steel
12	Seat	SS316, Stellite, Inconel
13	Seal Ring	SS316 + Graphite
14	Press Plate	ASTM A105 ASTM A182 F316
15	Hexagon Socket Head Bolt	ASTM A193 B7
16	Support Bolt	ASTM A193 B7
17	Spring Washer	ASTM A29 1566
18	Nut	ASTM A194 2H
19	Gland Bolt	ASTM A193 B7
20	Spring Washer	ASTM A29 1566
21	Nut	ASTM A194 2H

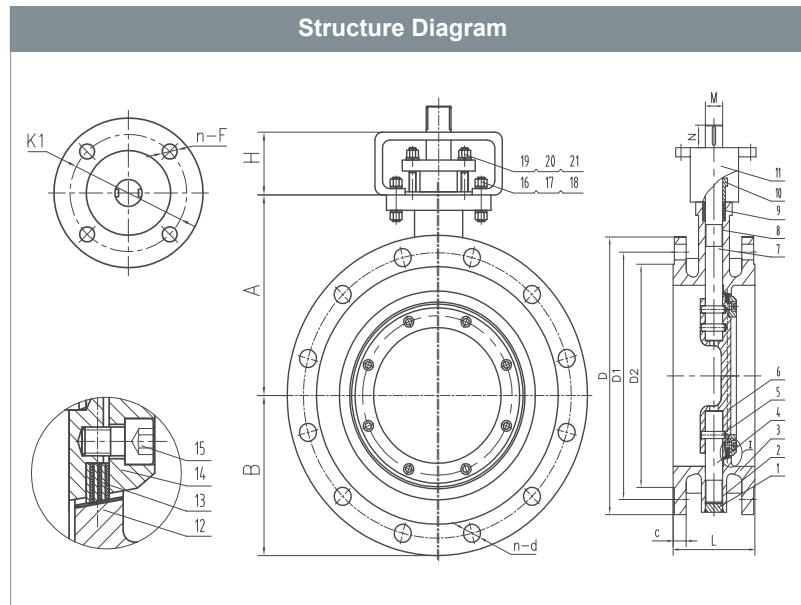

* For other materials and special requirements, consult factory or local offices.

Dimensions(300LB)													
In	L	D	D1	D2	C	n-d	H	A	B	M	N	K1	n-F
3	180	210	168.3	127	29	8-22	65	160	105	18	35	70	4-10
4	190	255	200	157.2	32.2	8-22	65	170	115	22	40	70	4-10
5	200	280	235	185.7	35.4	8-22	65	190	130	24	45	102	4-12
6	210	320	269.9	215.9	37	12-22	65	210	155	28	50	102	4-12
8	230	380	330.2	269.9	41.7	12-26	90	240	190	35	50	125	4-14
10	250	445	387.4	323.8	48.1	16-29	90	280	230	38	55	125	4-14
12	270	520	450.8	381	51.3	16-33	120	310	250	42	55	140	4-18
14	290	585	514.4	412.8	54.4	20-33	120	360	300	52	60	165	4-22
16	310	650	571.5	469.9	57.6	20-36	120	410	370	58	70	165	4-22
18	330	710	628.6	533.4	60.8	24-36	150	440	400	68	80	200	8-18
20	350	775	685.8	584.2	64	24-36	150	460	420	76	80	254	8-18
24	390	915	812.8	692.2	70.3	24-42	170	500	460	82	100	298	8-22

* For EN and other standards dimensions, consult factory.

Triple Eccentric Butterfly Valves Metal Seal, Flanged

1500PSI / Class600

Design to ASME B16.34/API609

Dimensions to ASME B16.5/B16.1/EN1092

Pressure Test to API598/ISO5208

Temperature Range: -50°C~650°C/-58°F~1200°F



HP5003-0

Materials List		
1	Lower End Cap	ASTM A105
2	Lower Shaft Sleeve	ASTM A276 304
3	Body	ASTM A216 WCB ASTM A351 CF8/CF8M
4	Lower Stem	ASTM A276 431 ASTM A564 630-17-4PH
5	Cylindrical Pin	ASTM A182 F304
6	Disc	ASTM A216 WCB ASTM A351 CF8/CF8M
7	Upper Stem	ASTM A276 431 ASTM A564 630-17-4PH
8	Upper Shaft Sleeve	ASTM A276 304
9	Packing	Graphite
10	Packing Gland	ASTM A216 WCB
11	Support	Carbon Steel
12	Seat	SS316, Stellite, Inconel
13	Seal Ring	SS316 + Graphite
14	Press Plate	ASTM A105 ASTM A182 F316
15	Hexagon Socket Head Bolt	ASTM A193 B7
16	Support Bolt	ASTM A193 B7
17	Spring Washer	ASTM A29 1566
18	Nut	ASTM A194 2H
19	Gland Bolt	ASTM A193 B7
20	Spring Washer	ASTM A29 1566
21	Nut	ASTM A194 2H

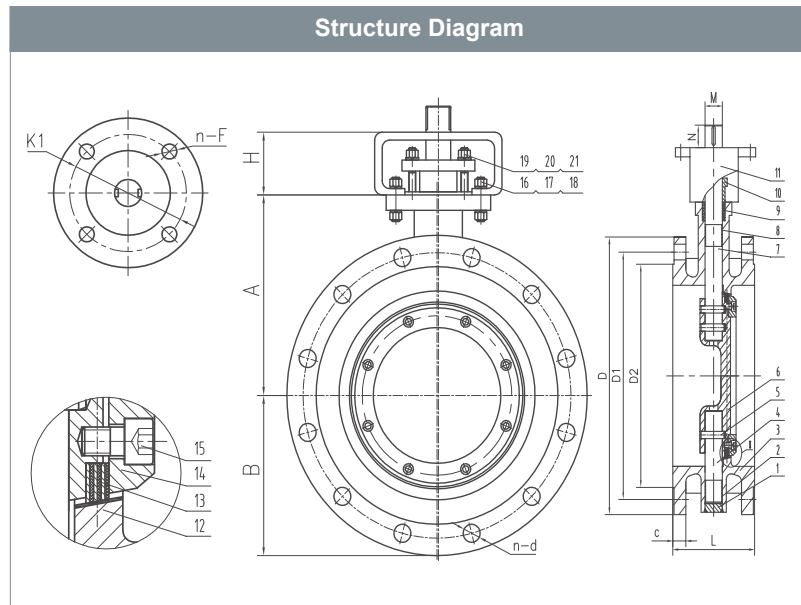

* For other materials and special requirements, consult factory or local offices.

Dimensions(600LB)													
In	L	D	D1	D2	C	n-d	H	A	B	M	N	K1	n-F
6	210	355	292.1	215.9	54.7	12-30	90	250	200	32	50	125	4-14
8	230	420	349.2	269.9	62.6	12-33	120	270	220	42	55	140	4-18
10	250	510	431.8	323.8	70.5	16-36	120	320	270	52	60	165	4-22
12	270	560	489	381	73.7	20-36	120	350	290	58	70	165	4-22
14	290	605	527	412.8	76.9	20-39	150	440	340	68	80	200	8-18
16	310	685	603.2	469.9	83.2	20-42	150	480	380	68	80	200	8-18
18	330	745	654	533.4	89.6	24-45	150	530	440	76	90	254	8-18
20	350	815	723.9	584.2	95.9	24-45	170	560	460	82	100	298	8-22
24	390	940	838.2	692.2	108.6	24-52	200	600	500	96	120	356	8-33

* For EN and other standards dimensions, consult factory.

Triple Eccentric Butterfly Valves Metal Seal, Wafer

300PSI / Class150
 Design to ASME B16.34/API609
 Dimensions to ASME B16.5/B16.1/EN1092
 Pressure Test to API598/ISO5208
 Temperature Range: -50°C~650°C/-58°F~1200°F



HP5103-1

Materials List		
1	Lower End Cap	ASTM A105
2	Lower Shaft Sleeve	ASTM A276 304
3	Body	ASTM A216 WCB ASTM A351 CF8/CF8M
4	Lower Stem	ASTM A276 431 ASTM A564 630-17-4PH
5	Cylindrical Pin	ASTM A182 F304
6	Disc	ASTM A216 WCB ASTM A351 CF8/CF8M
7	Upper Stem	ASTM A276 431 ASTM A564 630-17-4PH
8	Upper Shaft Sleeve	ASTM A276 304
9	Packing	Graphite
10	Packing Gland	ASTM A216 WCB
11	Support	Carbon Steel
12	Seat	SS316, Stellite, Inconel
13	Seal Ring	SS316 + Graphite
14	Press Plate	ASTM A105 ASTM A182 F316
15	Hexagon Socket Head Bolt	ASTM A193 B7
16	Support Bolt	ASTM A193 B7
17	Spring Washer	ASTM A29 1566
18	Nut	ASTM A194 2H
19	Gland Bolt	ASTM A193 B7
20	Spring Washer	ASTM A29 1566
21	Nut	ASTM A194 2H

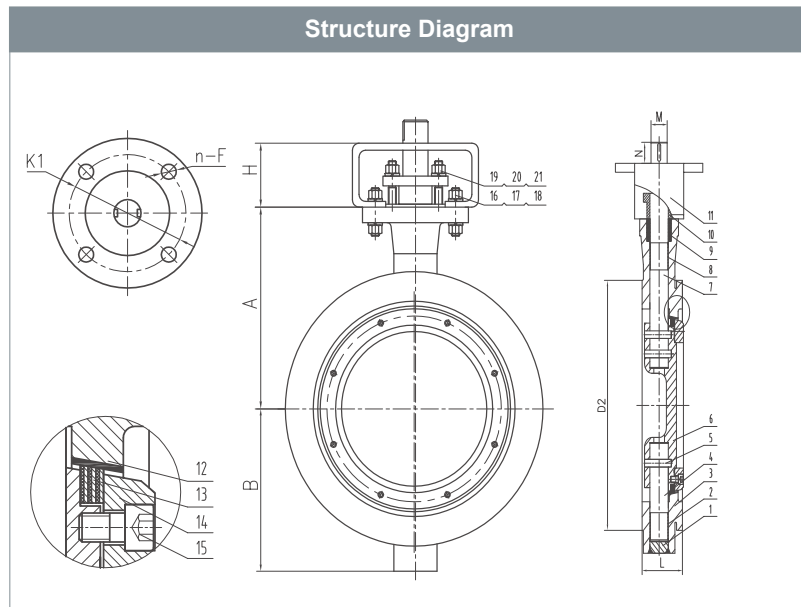

* For other materials and special requirements, consult factory or local offices.

Dimensions(150LB)									
In	L	D2	H	A	B	M	N	K1	n-F
3	48	127	65	150	95	16	35	70	4-10
4	54	157.2	65	156	102	20	35	70	4-10
5	56	185.7	65	178	117	22	35	70	4-10
6	57	215.9	65	190	134	26	45	102	4-12
8	64	269.9	90	220	170	32	55	125	4-14
10	71	323.8	90	258	207	36	60	125	4-14
12	81	381	90	290	230	38	65	140	4-18
14	92	412.8	120	330	270	46	70	140	4-18
16	102	469.9	120	330	270	46	70	140	4-18
18	114	533.4	120	390	355	58	90	200	8-18
20	127	584.2	120	410	370	68	100	254	8-18
24	154	692.2	150	480	430	76	120	298	8-22

* For EN and other standards dimensions, consult factory.

Triple Eccentric Butterfly Valves Metal Seal, Wafer

300PSI / Class150
 Design to ASME B16.34/API609
 Dimensions to ASME B16.5/B16.1/EN1092
 Pressure Test to API598/ISO5208
 Temperature Range: -50°C~650°C/-58°F~1200°F



HP5103-1

Materials List		
1	Lower End Cap	ASTM A105
2	Lower Shaft Sleeve	ASTM A276 304
3	Body	ASTM A216 WCB ASTM A351 CF8/CF8M
4	Lower Stem	ASTM A276 431 ASTM A564 630-17-4PH
5	Cylindrical Pin	ASTM A182 F304
6	Disc	ASTM A216 WCB ASTM A351 CF8/CF8M
7	Upper Stem	ASTM A276 431 ASTM A564 630-17-4PH
8	Upper Shaft Sleeve	ASTM A276 304
9	Packing	Graphite
10	Packing Gland	ASTM A216 WCB
11	Support	Carbon Steel
12	Seat	SS316, Stellite, Inconel
13	Seal Ring	SS316 + Graphite
14	Press Plate	ASTM A105 ASTM A182 F316
15	Hexagon Socket Head Bolt	ASTM A193 B7
16	Support Bolt	ASTM A193 B7
17	Spring Washer	ASTM A29 1566
18	Nut	ASTM A194 2H
19	Gland Bolt	ASTM A193 B7
20	Spring Washer	ASTM A29 1566
21	Nut	ASTM A194 2H

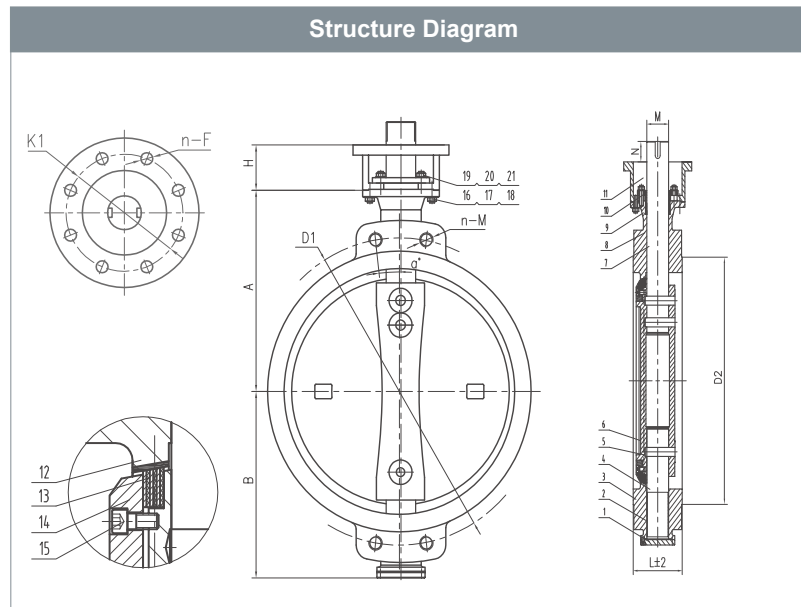

*For other materials and special requirements, consult factory or local offices.

Dimensions(150LB)											
In	L	D1	D2	n-M	H	A	B	M	N	K1	n-F
2 8	165	795.3	762	4-M20	150	530	490	82	130	356	8-33
3 2	190	900.1	864	4-M20	150	615	555	96	140	356	8-33
3 6	203	1009.6	972	4-M27	170	675	595	106	150	356	8-33
4 0	216	1120.8	1080	4-M27	170	980	750	116	160	406	8-39
4 8	254	1335.1	1289	4-M30	200	1100	870	136	160	483	12-39
5 6	390	1436.7	1391	4-M30	200	1180	930	156	170	483	12-39

* For EN and other standards dimensions, consult factory.

Triple Eccentric Butterfly Valves Metal Seal, Wafer

600PSI / Class300
 Design to ASME B16.34/API609
 Dimensions to ASME B16.5/B16.1/EN1092
 Pressure Test to API598/ISO5208
 Temperature Range: -50°C~650°C/-58°F~1200°F



HP5103-2

Materials List		
1	Lower End Cap	ASTM A105
2	Lower Shaft Sleeve	ASTM A276 304
3	Body	ASTM A216 WCB ASTM A351 CF8/CF8M
4	Lower Stem	ASTM A276 431 ASTM A564 630-17-4PH
5	Cylindrical Pin	ASTM A182 F304
6	Disc	ASTM A216 WCB ASTM A351 CF8/CF8M
7	Upper Stem	ASTM A276 431 ASTM A564 630-17-4PH
8	Upper Shaft Sleeve	ASTM A276 304
9	Packing	Graphite
10	Packing Gland	ASTM A216 WCB
11	Support	Carbon Steel
12	Seat	SS316, Stellite, Inconel
13	Seal Ring	SS316 + Graphite
14	Press Plate	ASTM A105 ASTM A182 F316
15	Hexagon Socket Head Bolt	ASTM A193 B7
16	Support Bolt	ASTM A193 B7
17	Spring Washer	ASTM A29 1566
18	Nut	ASTM A194 2H
19	Gland Bolt	ASTM A193 B7
20	Spring Washer	ASTM A29 1566
21	Nut	ASTM A194 2H

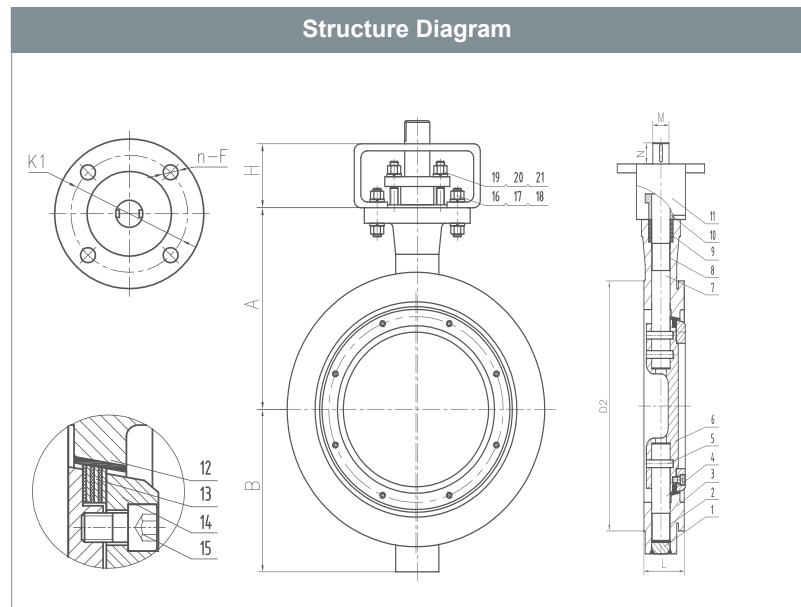

*For other materials and special requirements, consult factory or local offices.

Dimensions(300LB)									
In	L	D2	H	A	B	M	N	K1	n-F
3	48	127	65	160	105	18	35	70	4-10
4	54	157.2	65	170	115	22	40	70	4-10
5	56	185.7	65	190	130	24	45	102	4-12
6	59	215.9	65	210	155	28	50	102	4-12
8	73	269.9	90	240	190	35	50	125	4-14
10	83	323.8	90	280	230	38	55	125	4-14
12	92	381	120	310	250	42	55	140	4-18
14	117	412.8	120	360	300	52	60	165	4-22
16	133	469.9	120	410	370	58	70	165	4-22
18	149	533.4	150	440	400	68	80	200	8-18
20	159	584.2	150	460	420	76	80	254	8-18
24	181	692.2	170	500	460	82	100	298	8-22

* For EN and other standards dimensions, consult factory.

Triple Eccentric Butterfly Valves Metal Seal, Wafer

1500PSI / Class600
 Design to ASME B16.34/API609
 Dimensions to ASME B16.5/B16.1/EN1092
 Pressure Test to API598/ISO5208
 Temperature Range: -50°C~650°C/-58°F~1200°F



HP5103-0

Materials List		
1	Lower End Cap	ASTM A105
2	Lower Shaft Sleeve	ASTM A276 304
3	Body	ASTM A216 WCB ASTM A351 CF8/CF8M
4	Lower Stem	ASTM A276 431 ASTM A564 630-17-4PH
5	Cylindrical Pin	ASTM A182 F304
6	Disc	ASTM A216 WCB ASTM A351 CF8/CF8M
7	Upper Stem	ASTM A276 431 ASTM A564 630-17-4PH
8	Upper Shaft Sleeve	ASTM A276 304
9	Packing	Graphite
10	Packing Gland	ASTM A216 WCB
11	Support	Carbon Steel
12	Seat	SS316, Stellite, Inconel
13	Seal Ring	SS316 + Graphite
14	Press Plate	ASTM A105 ASTM A182 F316
15	Hexagon Socket Head Bolt	ASTM A193 B7
16	Support Bolt	ASTM A193 B7
17	Spring Washer	ASTM A29 1566
18	Nut	ASTM A194 2H
19	Gland Bolt	ASTM A193 B7
20	Spring Washer	ASTM A29 1566
21	Nut	ASTM A194 2H

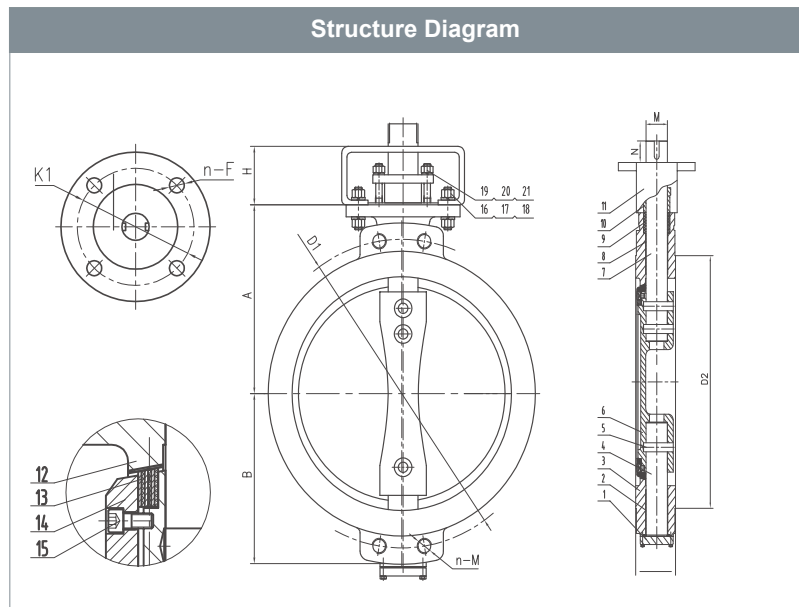

* For other materials and special requirements, consult factory or local offices.

Dimensions(600LB)											
In	L	D1	D2	H	A	B	M	N	K1	n-F	n-M
6	78	292.1	215.9	90	250	200	32	50	125	4-14	4-M30
8	102	349.2	269.9	120	270	220	42	55	140	4-18	4-M33
10	117	431.8	323.8	120	320	270	52	60	165	4-22	4-M33
12	140	489	381	120	350	290	58	70	165	4-22	4-M33
14	155	527	412.8	150	440	340	68	80	200	8-18	4-M36
16	178	603.2	469.9	150	480	380	68	80	200	8-18	4-M39
18	200	654	533.4	150	530	440	76	90	254	8-18	4-M42
20	216	723.9	584.2	170	560	460	82	100	298	8-22	4-M42
24	232	838.2	692.2	200	600	500	96	120	356	8-33	4-M42

* For EN and other standards dimensions, consult factory.

Triple Eccentric Butterfly Valves Metal Seal, Lug

300PSI / Class150

Design to ASME B16.34/API609

Dimensions to ASME B16.5/B16.1/EN1092

Pressure Test to API598/ISO5208

Temperature Range: -50°C~650°C/-58°F~1200°F



HP5203-1

Materials List		
1	Lower End Cap	ASTM A105
2	Lower Shaft Sleeve	ASTM A276 304
3	Body	ASTM A216 WCB ASTM A351 CF8/CF8M
4	Lower Stem	ASTM A276 431 ASTM A564 630-17-4PH
5	Cylindrical Pin	ASTM A182 F304
6	Disc	ASTM A216 WCB ASTM A351 CF8/CF8M
7	Upper Stem	ASTM A276 431 ASTM A564 630-17-4PH
8	Upper Shaft Sleeve	ASTM A276 304
9	Packing	Graphite
10	Packing Gland	ASTM A216 WCB
11	Support	Carbon Steel
12	Seat	SS316, Stellite, Inconel
13	Seal Ring	SS316 + Graphite
14	Press Plate	ASTM A105 ASTM A182 F316
15	Hexagon Socket Head Bolt	ASTM A193 B7
16	Support Bolt	ASTM A193 B7
17	Spring Washer	ASTM A29 1566
18	Nut	ASTM A194 2H
19	Gland Bolt	ASTM A193 B7
20	Spring Washer	ASTM A29 1566
21	Nut	ASTM A194 2H

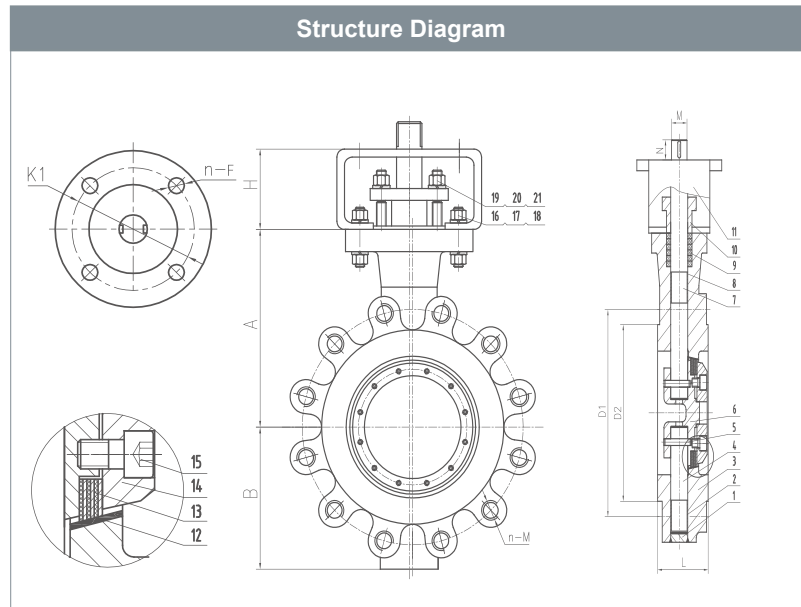

* For other materials and special requirements, consult factory or local offices.

Dimensions(150LB)											
In	L	D1	D2	n-M	H	A	B	M	N	K1	n-F
3	48	152.4	127	4-M16	65	150	95	16	35	70	4-10
4	54	190.5	157.2	8-M16	65	156	102	20	35	70	4-10
5	56	215.9	185.7	8-M20	65	178	117	22	35	70	4-10
6	57	241.3	215.9	8-M20	65	190	134	26	45	102	4-12
8	64	298.5	269.9	8-M20	90	220	170	32	55	125	4-14
10	71	360	323.8	12-M24	90	258	207	36	60	125	4-14
12	81	431.8	381	12-M24	90	290	230	38	65	140	4-18
14	92	476.3	412.8	12-M27	120	330	270	46	70	140	4-18
16	102	539.8	469.9	16-M27	120	378	340	52	80	165	4-22
18	114	577.9	533.4	16-M30	120	390	355	58	90	200	8-18
20	127	635	584.2	20-M30	120	410	370	68	100	254	8-18
24	154	749.3	692.2	20-M33	150	480	430	76	120	298	8-22

* For EN and other standards dimensions, consult factory.

Triple Eccentric Butterfly Valves Metal Seal, Lug

300PSI / Class150

Design to ASME B16.34/API609

Dimensions to ASME B16.5/B16.1/EN1092

Pressure Test to API598/ISO5208

Temperature Range: -50°C~650°C/-58°F~1200°F



HP5203-1

Materials List		
1	Lower End Cap	ASTM A105
2	Lower Shaft Sleeve	ASTM A276 304
3	Body	ASTM A216 WCB ASTM A351 CF8/CF8M
4	Lower Stem	ASTM A276 431 ASTM A564 630-17-4PH
5	Cylindrical Pin	ASTM A182 F304
6	Disc	ASTM A216 WCB ASTM A351 CF8/CF8M
7	Upper Stem	ASTM A276 431 ASTM A564 630-17-4PH
8	Upper Shaft Sleeve	ASTM A276 304
9	Packing	Graphite
10	Packing Gland	ASTM A216 WCB
11	Support	Carbon Steel
12	Seat	SS316, Stellite, Inconel
13	Seal Ring	SS316 + Graphite
14	Press Plate	ASTM A105 ASTM A182 F316
15	Hexagon Socket Head Bolt	ASTM A193 B7
16	Support Bolt	ASTM A193 B7
17	Spring Washer	ASTM A29 1566
18	Nut	ASTM A194 2H
19	Gland Bolt	ASTM A193 B7
20	Spring Washer	ASTM A29 1566
21	Nut	ASTM A194 2H

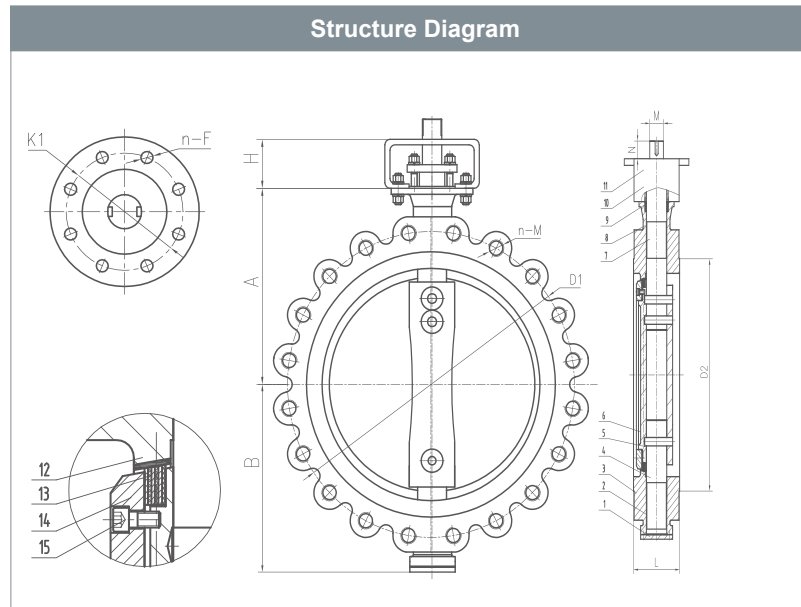

* For other materials and special requirements, consult factory or local offices.

Dimensions(150LB)											
In	L	D1	D2	n-M	H	A	B	M	N	K1	n-F
2 8	165	795.3	762	40-M20	150	530	490	82	130	356	8-33
3 2	190	900.1	864	48-M20	150	615	555	96	140	356	8-33
3 6	203	1009.6	972	44-M27	170	675	595	106	150	356	8-33
4 0	216	1120.8	1080	44-M27	170	980	750	116	160	406	8-39
4 8	254	1335.1	1289	44-M30	200	1100	870	136	160	483	12-39
5 6	390	1436.7	1391	52-M30	200	1180	930	156	170	483	12-39

* For EN and other standards dimensions, consult factory.

Triple Eccentric Butterfly Valves Metal Seal, Lug

600PSI / Class300
 Design to ASME B16.34/API609
 Dimensions to ASME B16.5/B16.1/EN1092
 Pressure Test to API598/ISO5208
 Temperature Range: -50°C~650°C/-58°F~1200°F



HP5203-2

Materials List		
1	Lower End Cap	ASTM A105
2	Lower Shaft Sleeve	ASTM A276 304
3	Body	ASTM A216 WCB ASTM A351 CF8/CF8M
4	Lower Stem	ASTM A276 431 ASTM A564 630-17-4PH
5	Cylindrical Pin	ASTM A182 F304
6	Disc	ASTM A216 WCB ASTM A351 CF8/CF8M
7	Upper Stem	ASTM A276 431 ASTM A564 630-17-4PH
8	Upper Shaft Sleeve	ASTM A276 304
9	Packing	Graphite
10	Packing Gland	ASTM A216 WCB
11	Support	Carbon Steel
12	Seat	SS316, Stellite, Inconel
13	Seal Ring	SS316 + Graphite
14	Press Plate	ASTM A105 ASTM A182 F316
15	Hexagon Socket Head Bolt	ASTM A193 B7
16	Support Bolt	ASTM A193 B7
17	Spring Washer	ASTM A29 1566
18	Nut	ASTM A194 2H
19	Gland Bolt	ASTM A193 B7
20	Spring Washer	ASTM A29 1566
21	Nut	ASTM A194 2H

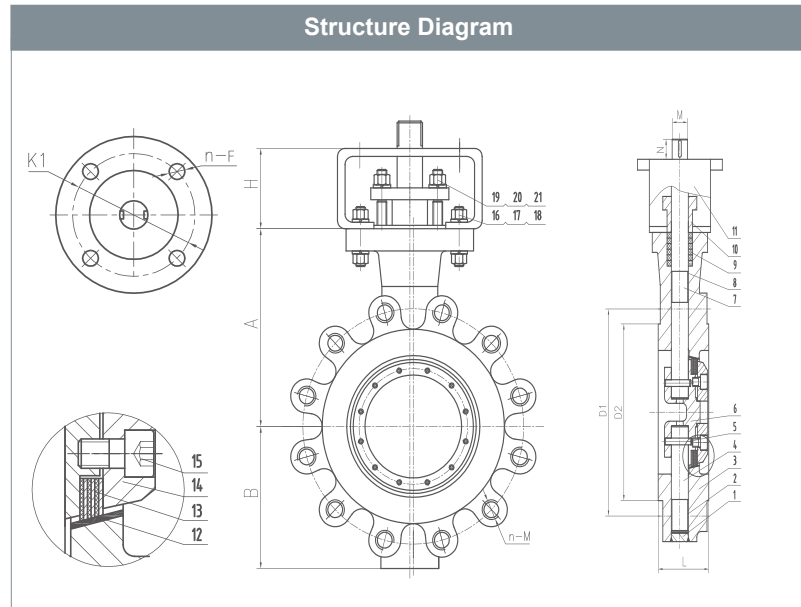

* For other materials and special requirements, consult factory or local offices.

Dimensions(300LB)											
In	L	D1	D2	n-M	H	A	B	M	N	K1	n-F
3	48	168.3	127	4-M20	65	160	105	18	35	70	4-10
4	54	200	157.2	8-M20	65	170	115	22	40	70	4-10
5	56	235	185.7	8-M20	65	190	130	24	45	102	4-12
6	59	269.9	215.9	12-M20	65	210	155	28	50	102	4-12
8	73	330.2	269.9	12-M24	90	240	190	35	50	125	4-14
10	83	387.4	323.8	16-M27	90	280	230	38	55	125	4-14
12	92	450.8	381	16-M30	120	310	250	42	55	140	4-18
14	117	514.4	412.8	20-M30	120	360	300	52	60	165	4-22
16	133	571.5	469.9	20-M33	120	410	370	58	70	165	4-22
18	149	628.6	533.4	24-M33	150	440	400	68	80	200	8-18
20	159	685.8	584.2	24-M33	150	460	420	76	80	254	8-18
24	181	812.8	692.2	24-M39	170	500	460	82	100	298	8-22

* For EN and other standards dimensions, consult factory.

Triple Eccentric Butterfly Valves Metal Seal, Lug

1500PSI / Class600
 Design to ASME B16.34/API609
 Dimensions to ASME B16.5/B16.1/EN1092
 Pressure Test to API598/ISO5208
 Temperature Range: -50°C~650°C/-58°F~1200°F



HP5203-0

Materials List		
1	Lower End Cap	ASTM A105
2	Lower Shaft Sleeve	ASTM A276 304
3	Body	ASTM A216 WCB ASTM A351 CF8/CF8M
4	Lower Stem	ASTM A276 431 ASTM A564 630-17-4PH
5	Cylindrical Pin	ASTM A182 F304
6	Disc	ASTM A216 WCB ASTM A351 CF8/CF8M
7	Upper Stem	ASTM A276 431 ASTM A564 630-17-4PH
8	Upper Shaft Sleeve	ASTM A276 304
9	Packing	Graphite
10	Packing Gland	ASTM A216 WCB
11	Support	Carbon Steel
12	Seat	SS316, Stellite, Inconel
13	Seal Ring	SS316 + Graphite
14	Press Plate	ASTM A105 ASTM A182 F316
15	Hexagon Socket Head Bolt	ASTM A193 B7
16	Support Bolt	ASTM A193 B7
17	Spring Washer	ASTM A29 1566
18	Nut	ASTM A194 2H
19	Gland Bolt	ASTM A193 B7
20	Spring Washer	ASTM A29 1566
21	Nut	ASTM A194 2H

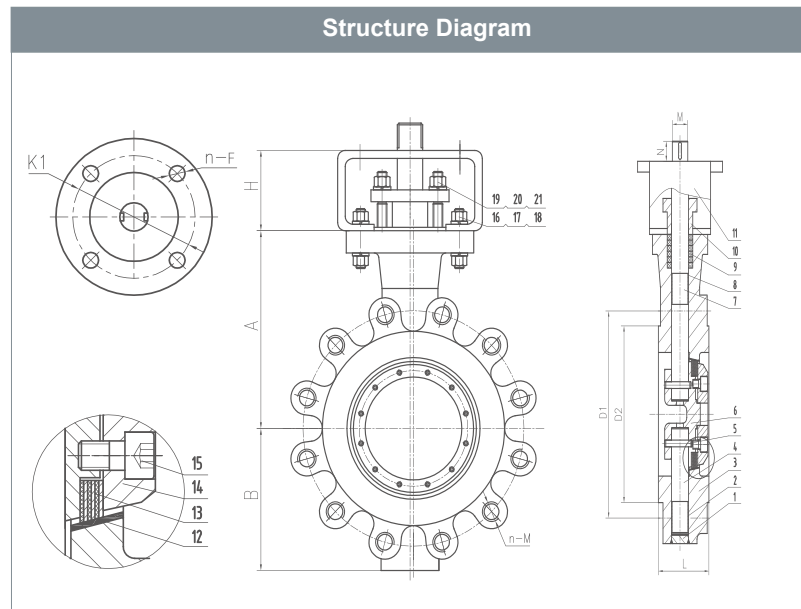

* For other materials and special requirements, consult factory or local offices.

Dimensions(600LB)											
In	L	D1	D2	n-M	H	A	B	M	N	K1	n-F
6	78	292.1	215.9	12-M27	90	250	200	32	50	125	4-14
8	102	349.2	269.9	12-M30	120	270	220	42	55	140	4-18
10	117	431.8	323.8	16-M33	120	320	270	52	60	165	4-22
12	140	489	381	20-M33	120	350	290	58	70	165	4-22
14	155	527	412.8	20-M36	150	440	340	68	80	200	8-18
16	178	603.2	469.9	20-M39	150	480	380	68	80	200	8-18
18	200	654	533.4	20-M42	150	530	440	76	90	254	8-18
20	216	723.9	584.2	24-M42	170	560	460	82	100	298	8-22
24	232	838.2	692.2	24-M48	200	600	500	96	120	356	8-33

* For EN and other standards dimensions, consult factory.

Triple Eccentric Butterfly Valves Metal Seal, Welded

300PSI / Class150
 Design to ASME B16.34/API609
 Dimensions to ASME B16.5/B16.1/EN1092
 Pressure Test to API598/ISO5208
 Temperature Range: -50°C ~ 650°C / -58°F ~ 1200°F

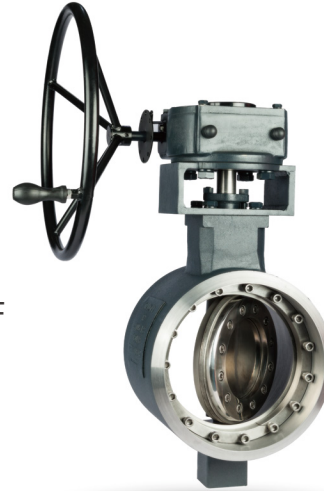

HP5303-1

Materials List		
1	Lower End Cap	ASTM A105
2	Lower Shaft Sleeve	ASTM A276 304
3	Body	ASTM A216 WCB ASTM A351 CF8/CF8M
4	Lower Stem	ASTM A276 431 ASTM A564 630-17-4PH
5	Cylindrical Pin	ASTM A182 F304
6	Disc	ASTM A216 WCB ASTM A351 CF8/CF8M
7	Upper Stem	ASTM A276 431 ASTM A564 630-17-4PH
8	Upper Shaft Sleeve	ASTM A276 304
9	Packing	Graphite
10	Packing Gland	ASTM A216 WCB
11	Support	Carbon Steel
12	Seat	SS316, Stellite, Inconel
13	Seal Ring	SS316 + Graphite
14	Press Plate	ASTM A105 ASTM A182 F316
15	Hexagon Socket Head Bolt	ASTM A193 B7
16	Support Bolt	ASTM A193 B7
17	Spring Washer	ASTM A29 1566
18	Nut	ASTM A194 2H
19	Gland Bolt	ASTM A193 B7
20	Spring Washer	ASTM A29 1566
21	Nut	ASTM A194 2H

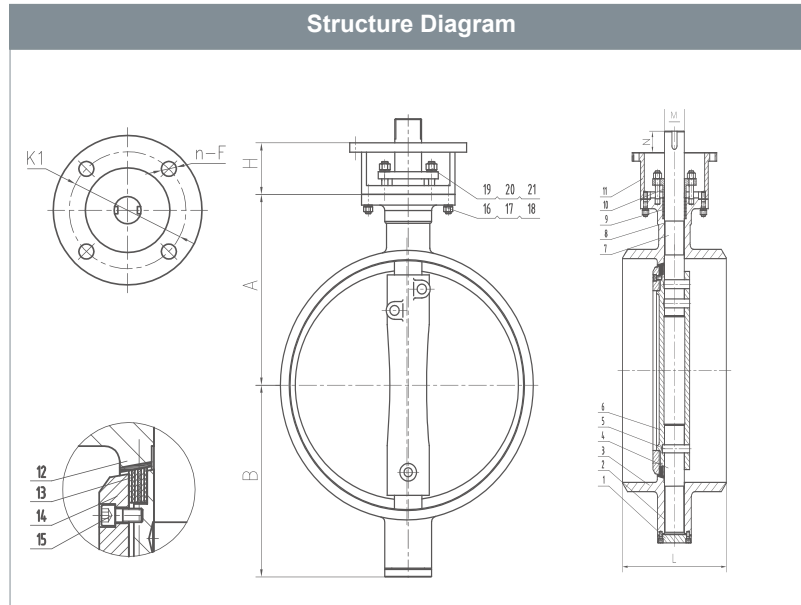

* For other materials and special requirements, consult factory or local offices.

Dimensions(150LB)								
In	L	H	A	B	M	N	K1	n-F
3	180	65	150	95	16	35	70	4-10
4	190	65	156	102	20	35	70	4-10
5	200	65	178	117	22	35	70	4-10
6	210	65	190	134	26	45	102	4-12
8	230	90	220	170	32	55	125	4-14
10	250	90	258	207	36	60	125	4-14
12	270	90	290	230	38	65	140	4-18
14	290	120	330	270	46	70	140	4-18
16	310	120	378	340	52	80	165	4-22
18	330	120	390	355	58	90	200	8-18
20	350	120	410	370	68	100	254	8-18
24	390	150	480	430	76	120	298	8-22

* For EN and other standards dimensions, consult factory.

Triple Eccentric Butterfly Valves Metal Seal, Welded

300PSI / Class150
 Design to ASME B16.34/API609
 Dimensions to ASME B16.5/B16.1/EN1092
 Pressure Test to API598/ISO5208
 Temperature Range: -50°C ~ 650°C / -58°F ~ 1200°F

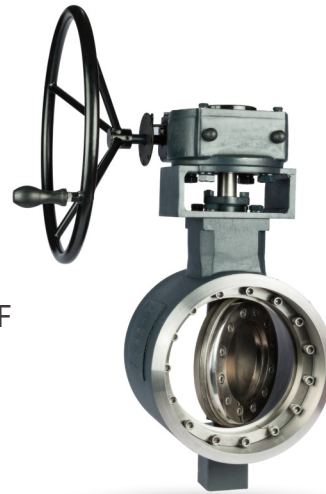

HP5303-1

Materials List		
1	Lower End Cap	ASTM A105
2	Lower Shaft Sleeve	ASTM A276 304
3	Body	ASTM A216 WCB ASTM A351 CF8/CF8M
4	Lower Stem	ASTM A276 431 ASTM A564 630-17-4PH
5	Cylindrical Pin	ASTM A182 F304
6	Disc	ASTM A216 WCB ASTM A351 CF8/CF8M
7	Upper Stem	ASTM A276 431 ASTM A564 630-17-4PH
8	Upper Shaft Sleeve	ASTM A276 304
9	Packing	Graphite
10	Packing Gland	ASTM A216 WCB
11	Support	Carbon Steel
12	Seat	SS316, Stellite, Inconel
13	Seal Ring	SS316 + Graphite
14	Press Plate	ASTM A105 ASTM A182 F316
15	Hexagon Socket Head Bolt	ASTM A193 B7
16	Support Bolt	ASTM A193 B7
17	Spring Washer	ASTM A29 1566
18	Nut	ASTM A194 2H
19	Gland Bolt	ASTM A193 B7
20	Spring Washer	ASTM A29 1566
21	Nut	ASTM A194 2H

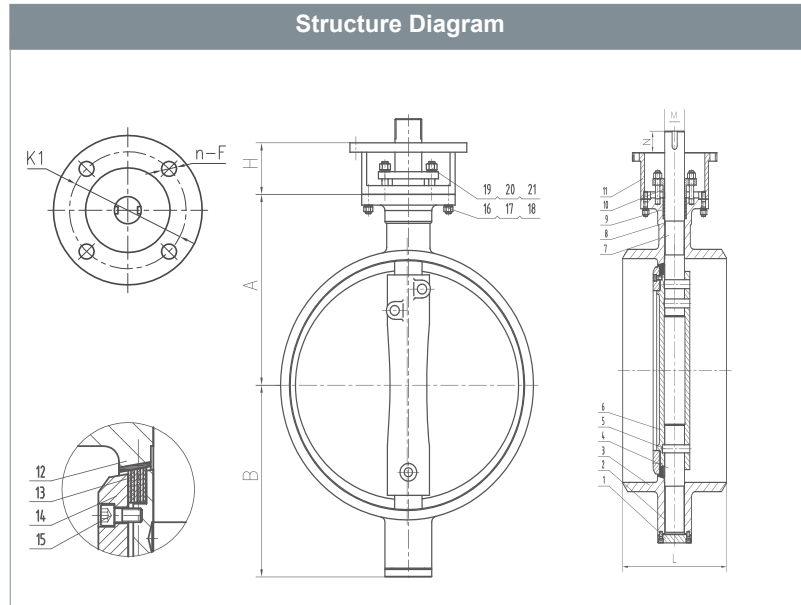

* For other materials and special requirements, consult factory or local offices.

Dimensions(150LB)								
In	L	H	A	B	M	N	K1	n-F
2.8	430	150	530	490	82	130	356	8-33
3.2	470	150	615	555	96	140	356	8-33
3.6	510	170	675	595	106	150	356	8-33
4.0	550	170	940	690	116	160	406	8-39
4.8	630	200	1100	850	136	160	483	12-39
5.6	710	200	1180	900	156	170	483	12-39

* For EN and other standards dimensions, consult factory.

Triple Eccentric Butterfly Valves Metal Seal, Welded

600PSI / Class300
 Design to ASME B16.34/API609
 Dimensions to ASME B16.5/B16.1/EN1092
 Pressure Test to API598/ISO5208
 Temperature Range: -50°C~650°C/-58°F~1200°F

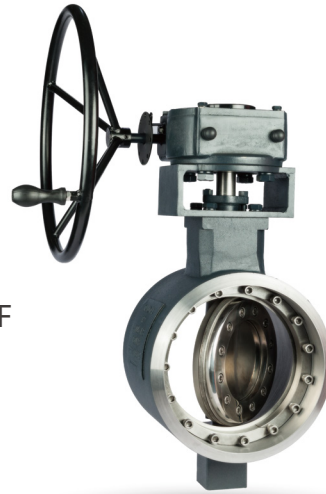

HP5303-2

Materials List		
1	Lower End Cap	ASTM A105
2	Lower Shaft Sleeve	ASTM A276 304
3	Body	ASTM A216 WCB ASTM A351 CF8/CF8M
4	Lower Stem	ASTM A276 431 ASTM A564 630-17-4PH
5	Cylindrical Pin	ASTM A182 F304
6	Disc	ASTM A216 WCB ASTM A351 CF8/CF8M
7	Upper Stem	ASTM A276 431 ASTM A564 630-17-4PH
8	Upper Shaft Sleeve	ASTM A276 304
9	Packing	Graphite
10	Packing Gland	ASTM A216 WCB
11	Support	Carbon Steel
12	Seat	SS316, Stellite, Inconel
13	Seal Ring	SS316 + Graphite
14	Press Plate	ASTM A105 ASTM A182 F316
15	Hexagon Socket Head Bolt	ASTM A193 B7
16	Support Bolt	ASTM A193 B7
17	Spring Washer	ASTM A29 1566
18	Nut	ASTM A194 2H
19	Gland Bolt	ASTM A193 B7
20	Spring Washer	ASTM A29 1566
21	Nut	ASTM A194 2H

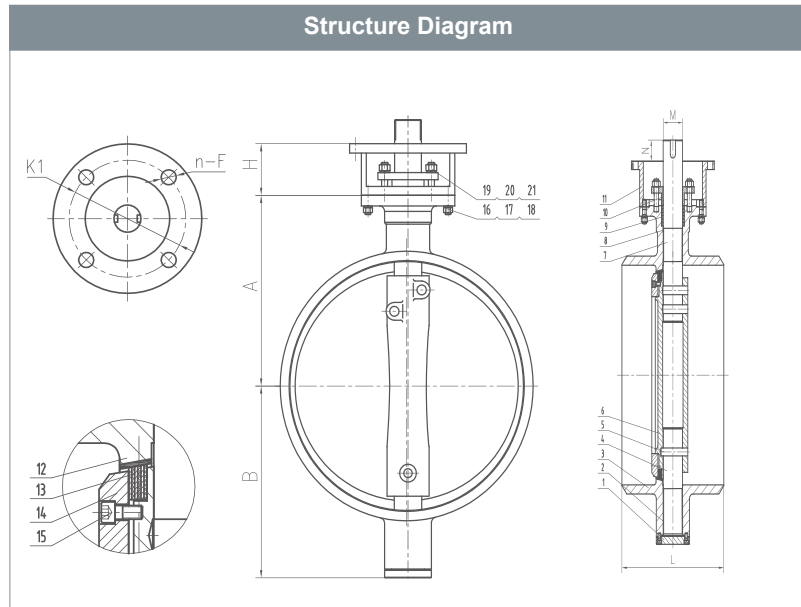

* For other materials and special requirements, consult factory or local offices.

Dimensions(300LB)								
In	L	H	A	B	M	N	K1	n-F
3	180	65	160	105	18	35	70	4-10
4	190	65	170	115	22	40	70	4-10
5	200	65	190	130	24	45	102	4-12
6	210	65	210	155	28	50	102	4-12
8	230	90	240	190	35	50	125	4-14
10	250	90	280	230	38	55	125	4-14
12	270	120	310	250	42	55	140	4-18
14	290	120	360	300	52	60	165	4-22
16	310	120	410	370	58	70	165	4-22
18	330	150	440	400	68	80	200	8-18
20	350	150	460	420	76	80	254	8-18
24	390	170	500	460	82	100	298	8-22

* For EN and other standards dimensions, consult factory.

Triple Eccentric Butterfly Valves Metal Seal, Welded

1500PSI / Class600

Design to ASME B16.34/API609

Dimensions to ASME B16.5/B16.1/EN1092

Pressure Test to API598/ISO5208

Temperature Range: -50°C ~ 650°C / -58°F ~ 1200°F



HP5303-0

Materials List		
1	Lower End Cap	ASTM A105
2	Lower Shaft Sleeve	ASTM A276 304
3	Body	ASTM A216 WCB ASTM A351 CF8/CF8M
4	Lower Stem	ASTM A276 431 ASTM A564 630-17-4PH
5	Cylindrical Pin	ASTM A182 F304
6	Disc	ASTM A216 WCB ASTM A351 CF8/CF8M
7	Upper Stem	ASTM A276 431 ASTM A564 630-17-4PH
8	Upper Shaft Sleeve	ASTM A276 304
9	Packing	Graphite
10	Packing Gland	ASTM A216 WCB
11	Support	Carbon Steel
12	Seat	SS316, Stellite, Inconel
13	Seal Ring	SS316 + Graphite
14	Press Plate	ASTM A105 ASTM A182 F316
15	Hexagon Socket Head Bolt	ASTM A193 B7
16	Support Bolt	ASTM A193 B7
17	Spring Washer	ASTM A29 1566
18	Nut	ASTM A194 2H
19	Gland Bolt	ASTM A193 B7
20	Spring Washer	ASTM A29 1566
21	Nut	ASTM A194 2H

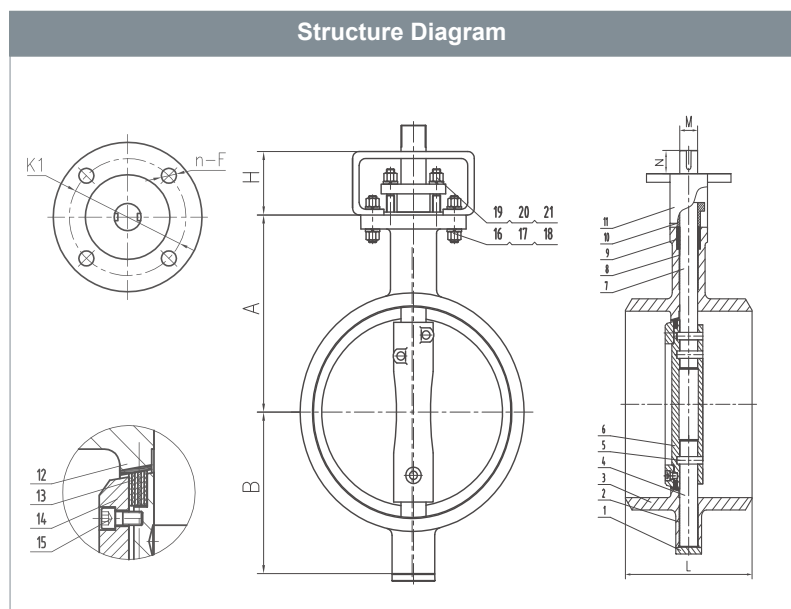

* For other materials and special requirements, consult factory or local offices.

Dimensions(600LB)								
In	L	H	A	B	M	N	K1	n-F
6	210	90	250	200	32	50	125	4-14
8	230	120	270	220	42	55	140	4-18
10	250	120	320	270	52	60	165	4-22
12	270	120	350	290	58	70	165	4-22
14	290	150	440	340	68	80	200	8-18
16	310	150	480	380	68	80	200	8-18
18	330	150	530	440	76	90	254	8-18
20	350	170	560	460	82	100	298	8-22
24	390	200	600	500	96	120	356	8-33

* For EN and other standards dimensions, consult factory.

Kvs Flow Parameters

The Kvs values (m³/h) listed below are the reference flows when the water temperature is within 5°C~30°C (41°F~85°F) and the pressure differential is $\Delta P=1$ bar.

Size		150LB							
		Opening Angle							
In	mm	10°	20°	30°	40°	50°	60°	70°	80°
3	80	5	19	33	46	60	82	109	133
4	100	10	36	62	83	111	150	200	244
6	150	27	50	86	152	254	383	527	650
8	200	49	93	158	280	466	703	968	1191
10	250	85	160	274	485	807	1216	1679	2065
12	300	126	239	409	724	1208	1816	2502	3084
14	350	172	326	558	985	1645	2476	3410	4190
16	400	268	508	874	1541	2562	3864	5321	6546
18	450	353	670	1148	2030	3387	5089	7009	8654
20	500	436	827	1413	2502	3164	6289	8654	10625
24	600	628	1191	2039	3607	5998	9083	12425	15338
28	700	908	1722	2956	5227	8655	13110	17990	22193
32	800	1173	2219	3805	6718	11139	16880	23222	28535
36	900	1439	2725	4670	8252	13710	20736	28534	35047
40	1000	1902	3608	6178	10882	18166	27335	37703	46358
48	1200	2674	5073	8655	15338	25535	38560	53042	65210

* For more data, please contact our engineers. TALOAR reserves the right to modify the parameters.

Size		300LB							
		Opening Angle							
In	mm	10°	20°	30°	40°	50°	60°	70°	80°
3	80	5	19	33	46	60	82	109	133
4	100	10	36	62	83	111	150	200	244
6	150	21	46	78	138	229	348	479	590
8	200	38	83	142	255	421	649	882	1079
10	250	70	152	258	462	763	1156	1593	1962
12	300	104	228	385	691	1139	1730	2382	2930
14	350	143	311	525	943	1550	2356	3239	3993
16	400	212	461	779	1396	2305	3504	4807	5929
18	450	279	608	1028	1842	3041	4610	6341	7806
20	500	345	750	1268	2270	3753	5689	7823	9682
24	600	497	1079	1825	3273	5407	8200	11225	13381
28	700	723	1576	2656	4764	7874	11910	16366	20222
32	800	951	2073	3496	6263	10368	15681	21593	26563
36	900	1208	2630	4447	7969	13198	19970	27499	33828
40	1000	1456	3161	5338	9597	15766	23990	32904	40616
48	1200	1748	3804	6426	11482	19023	28877	39674	48843

* For more data, please contact our engineers. TALOAR reserves the right to modify the parameters.

Kvs Flow Parameters

The Kvs values (m³/h) listed below are the reference flows when the water temperature is within 5°C~30°C (41°F~85°F) and the pressure differential is ΔP=1 bar.

Size		600LB							
		Opening Ongle							
In	mm	10°	20°	30°	40°	50°	60°	70°	80°
3	80	9	19	31	47	71	108	133	155
4	100	13	29	46	71	104	158	213	247
6	150	33	71	111	168	250	382	514	596
8	200	59	126	197	301	444	679	916	1061
10	250	93	203	313	479	709	1088	1457	1684
12	300	137	293	455	719	1033	1582	2122	2453
14	350	184	396	615	940	1391	2130	2862	3311
16	400	244	527	819	1251	1852	2835	3808	4401
18	450	317	684	1066	1629	2413	3712	4981	5757
20	500	385	829	1286	1965	2910	4457	5981	6913
24	600	562	1212	2393	2873	4251	6514	8740	10105

* For more data, please contact our engineers. TALUAR reserves the right to modify the parameters.

Pressure Vs Temperature material performance

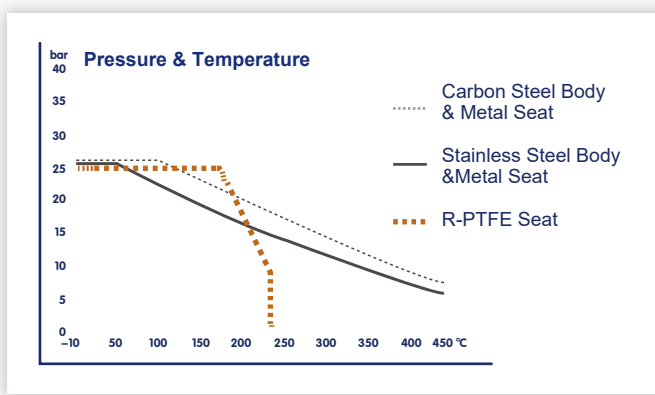

Kvs flow curve

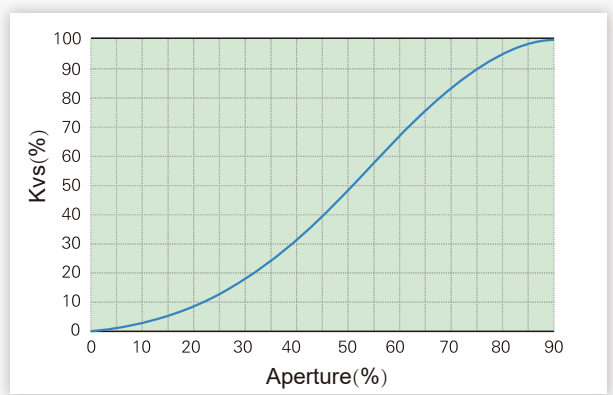

Torque (N.m)

LB	In	3	4	5	6	8	10	12	14	16
		150	200	200	300	400	1500	2000	2500	4000
300	600	600	1000	1500	2500	3000	5000	7000	10000	
600	/	/	/	2000	3000	4000	6000	9000	15000	
LB	In	18	20	24	28	32	36	40	48	56
		150	5000	7000	15000	20000	30000	35000	37000	52500

* For more data, please contact our engineers. TALUAR reserves the right to modify the parameters.

Pressure-temperature ratings

Valves conform to ANSI B16.34-1996 (Flanged, Threaded, and Welding End)

ASTM A216 GR.WCB							
Temperature		Working pressure			Class/PSI		
°F	°C	150	300	600	900	1500	2500
-20-100	-29-38	285	740	1480	2220	3705	6170
200	93	260	675	1350	2025	3375	5625
300	149	230	655	1315	1970	3280	5470
400	204	200	635	1270	1900	3170	5280
500	260	170	600	1200	1795	2995	4990
600	316	140	550	1095	1640	2735	4560
650	343	125	535	1075	1610	2685	4475
700	371	110	535	1065	1600	2665	4440
750	399	95	505	1010	1510	2520	4200
800	427	80	410	825	1235	2060	3430
850	454	65	270	535	805	1340	2230
900	482	50	170	345	515	860	1430
950	510	35	105	205	310	515	860
1000	538	20	50	105	155	260	430

* Note: A216WCB valves must not be operated at high temperature of 800°F (427°C) for a long time. The maximum operating temperature shall not exceed 1100°F (593°C).

ASTM A352 GR.LCB							
Temperature		Working pressure			Class/PSI		
°F	°C	150	300	600	900	1500	2500
-20-100	-29-38	265	695	1390	2085	3470	5785
200	93	250	655	1315	1970	3280	5470
300	149	230	640	1275	1915	3190	5315
400	204	200	620	1235	1850	3085	5145
500	260	170	585	1165	1745	2910	4850
600	316	140	535	1065	1600	2665	4440
650	343	125	525	1045	1570	2615	4355
700	371	110	520	1035	1555	2590	4320
750	399	95	475	945	1420	2365	3945
800	427	80	390	780	1175	1955	3260
850	454	65	270	535	805	1340	2230
900	482	50	170	345	515	860	1430
950	510	35	105	205	310	515	860
1000	538	20	50	105	155	260	430

* Note: The maximum operating temperature of A352LCB valves must not exceed 650°F (343°C).

Pressure-temperature ratings

Valves conform to ANSI B16.34-1996 (Flanged, Threaded, and Welding End)

ASTM A351 GR.CF8M							
Temperature		Working pressure			Class/PSI		
°F	°C	150	300	600	900	1500	2500
-20-100	-29-38	275	720	1440	2160	3600	6000
200	93	235	620	1240	1860	3095	5160
300	149	215	560	1120	1680	2795	4660
400	204	195	515	1025	1540	2570	4280
500	260	170	480	955	1435	2390	3980
600	316	140	450	900	1355	2255	3980
650	343	125	445	890	1330	2220	3700
700	371	110	430	870	1305	2170	3620
750	399	95	425	855	1280	2135	3560
800	427	80	420	845	1265	2110	3520
850	454	65	420	835	1255	2090	3480
900	482	50	415	830	1245	2075	3460
950	510	75	385	775	1160	1930	3220
1000	538	20	350	700	1050	1750	2915
1050	566	20	345	685	1030	1720	2865
1100	566	20	305	610	915	1525	2545
1150	621	20	235	475	710	1185	1970
1200	649	20	185	370	555	925	1545
1250	677	20	145	295	440	735	1230
1300	704	20	115	235	350	585	970
1350	732	20	95	190	290	480	800
1400	760	20	75	150	225	380	630
1450	788	20	115	115	175	290	485
1500	816	20	85	85	125	705	345

* Note: This table is subject to welding end valves operated at temperature of 1000°F (538°C) and below. Once the operating temperature is higher than 1000°F (538°C), valves materials containing more than 0.04% carbon are only allowed.

ASTM A217 GR.C5							
Temperature		Working pressure			Class/PSI		
°F	°C	150	300	600	900	1500	2500
-20-100	-29-38	290	750	1500	2250	3750	6250
200	93	260	745	1490	2235	3725	6205
300	149	230	715	1430	2150	3580	5965
400	204	200	705	1410	2115	3530	5880
500	260	170	665	1330	1995	3325	5340
600	316	140	605	1210	1815	3075	5040
650	343	125	590	1175	1765	2940	4905
700	371	110	570	1135	1705	2840	4730
750	399	95	530	1055	1585	2640	4400
800	427	80	510	1015	1525	2540	4230
850	454	65	485	965	1450	2415	4030
900	482	50	370	740	1110	1850	3085
950	510	35	275	550	825	1370	2285
1000	538	20	200	400	595	995	1655
1050	566	20	145	290	430	720	1240
1100	566	20	100	200	300	495	830
1150	621	20	60	125	185	310	515
1200	649	15	35	70	105	170	285

* Note: This table is for welded end valves only. Flange temperature is 1000°F (538°C) or above.

Materials and mechanical properties

ASTM NO.	Max. chemical contents (%)									Min. mechanical properties				Hardness
	C	Mn	P	S	Si	Cr	Mo	Ni	Cu	Tensile strength KSI	Yield strength KSI	Elongation %	Shrinkage %	
A105	0.35	1.05	0.035	0.040	0.35	0.30	0.12	0.40	0.40	485	250	30	30	≤ 187
A216 WCB	0.30	1.00	0.040	0.045	0.60	0.50	0.20	0.50	0.30	485	250	22	35	
A216 WCC	0.25	1.20	0.040	0.045	0.60	0.50	0.20	0.50	0.30	485	275	22	35	
A217 WC1	0.25	0.80	0.040	0.045	0.60		0.65		0.50	450	240	24	35	
A217 WC6	0.20	0.80	0.040	0.045	0.60	1.50	0.65		0.50	485	275	20	35	
A217 WC9	0.18	0.70	0.040	0.045	0.60	2.75	1.20		0.50	485	275	20	35	
A217 C5	0.20	0.70	0.040	0.045	0.75	6.50	0.65		0.50	620	415	18	35	
A217 CA15	0.15	1.00	0.040	0.040	1.50	14.00	0.50	1.00		620	450	18	30	
A351 CF8	0.08	1.50	0.040	0.040	2.00	21.00	0.50	11.00		485	205	35		
A351 CF8M	0.08	1.50	0.040	0.040	1.50	21.00	3.00	12.00		485	205	30		
A351 CF3	0.03	1.50	0.040	0.040	2.00	21.00	0.50	12.00		485	205	35		
A351 CF3M	0.03	1.50	0.040	0.040	1.50	21.00	3.00	13.00		485	205	30		
A351 CN7M	0.07	1.50	0.040	0.040	1.50	22.00	3.00	30.50	4.00	425	170	35		
A352 LCB	0.30	1.00	0.040	0.045	0.60	0.50	0.20	0.50	0.30	450	240	24	35	J(lbf · ft)18(13)
A352 LCC	0.25	1.20	0.040	0.045	0.60	0.50	0.20	0.50	0.30	485	275	22	35	J(lbf · ft)20(15)
A182 F6a	0.15	1.00	0.040	0.030	1.00	13.50		0.50		585	380	18	35	167–229
A182 F304	0.08	2.00	0.045	0.030	1.00	20.00		11.00		515	205	30	50	
A182 F316	0.08	2.00	0.045	0.030	1.00	18.00	3.00	14.00		515	205	30	50	
A182 F304L	0.035	2.00	0.045	0.030	1.00	20.00		13.00		485	170	30	50	
A182 F316L	0.035	2.00	0.045	0.030	1.00	18.00	3.00	15.00		485	170	30	50	
A276 410	0.15	1.00	0.040	0.030	1.00	13.50				690	550	15	45	
A276 420	≥ 0.15	1.00	0.040	0.030	1.00	14.00								≤ 241
A193 B7	0.49	1.10	0.035	0.040	0.35	1.20	0.25			860	720	16	50	
A193 B7M	0.49	1.10	0.035	0.040	0.35	1.20	0.25			690	550	18	50	HB235 HRB99
A193 B8	0.08	2.00	0.045	0.030	1.00	20.00		10.50		515	205	30	50	HB223 HRB96
A193 B8M	0.08	2.00	0.045	0.030	1.00	18.00	3.00	14.00		515	205	30	50	HB223 HRB96
A194 2H	0.40	1.00	0.040	0.050	0.40									HB248–352 HRC24–38
A194 2HM	0.40	1.00	0.040	0.050	0.40									HB159–237 HRC22
A320 L7	0.48	1.00	0.035	0.040	0.35	1.10	0.25			860	725	16	50	
A320 L7M	0.48	1.00	0.035	0.040	0.35	1.10	0.25			690	550	18	50	HB235 HRB99
A194 8	0.08	2.00	0.045	0.03	1.00	20		10.50						HB126–300 HRC60–105

Fire Protection

Resilient Wedge Gate Valve
Indicator Post
Butterfly Valve
Fire Hydrant
UL/FM

Oil Refining

Gate Valve
Globe Valve
Trunnion Ball Valve
High Performance Butterfly Valve
Plug Valve
API 609 API 6D

Power Plant

Metal Seal Ball Valve
Gate Valve
Globe Valve
Needle Valve
CS, FS, SS

Shipping

Bronze Valve
Butterfly Valve
Gate Valve
Ball Valve
Check Valve

Our Business

HVAC Systems

Hydraulic Balancing Valve
Differential Pressure Valve
Motorized Valve
Temperature Control
Bronze Valve & Iron Valve

Water Treatment

Flanged Butterfly Valve
Knife Gate Valve
Check Valve

Chemical

Bellows Globe Valve
Angle Valve
Metal Seal Ball Valve
High Performance Butterfly Valve

Irrigation

Solenoid Control Valve
Pressure Reducing Valve
Pressure Relief Valve
Diaphragm Valve
Butterfly Valve
Gate Valve



TALOAR®



TALOAR[®]

Taloar Changzhou

Building 22, No. 666 Dailuo Road,
Yaoguan Town, Economic Development
Zone, Changzhou 213000
Tel.: +86 519 89665598
www.taloarvalve.com