

GLOBAL FLOW CONTROL COMBINATION



Water Control Valve Solution

TALOAR[®]

TALOAR

TALOAR Your One Stop

Reliable Partner!

Taloor

is a world-leading supplier of flow control products and services, providing a diverse range of fluid control products that has wide applicability to commerce, water service and industry.

The solutions provided by Taloor constitute an important part of the leading plant asset management strategies.



Taloor

combines the latest mechanical technologies and advanced automation systems in its production to ensure our products consistently maintain excellent quality.

Taloor always cares and concerns for our users, which is not just a slogan, but a fundamental aspect ingrained in every decision and action taken by the company.

Taloor

has provided solutions and technical services for multiple projects around the world. We accumulated rich project experiences and helped users save energy, boost efficiency, and improve the environment. Through years of product experience and on-site service, Taloor has built up a good reputation in many industries and has become one of the preferred brands for owners and designers.

Fire Protection

- Resilient Wedge Gate Valve
- Indicator Post
- Butterfly Valve
- Fire Hydrant
- UL/FM

Oil Refining

- Gate Valve
- Globe Valve
- Trunnion Ball Valve
- High Performance Butterfly Valve
- Plug Valve
- API 609 API 6D

Shipping

- Bronze Valve
- Butterfly Valve
- Gate Valve
- Ball Valve
- Check Valve

Power Plant

- Metal Seal Ball Valve
- Gate Valve
- Globe Valve
- Needle Valve
- CS, FS, SS

Our Business

HVAC Systems

- Hydraulic Balancing Valve
- Differential Pressure Valve
- Motorized Valve
- Temperature Control
- Bronze Valve & Iron Valve

Chemical

- Bellows Globe Valve
- Angle Valve
- Metal Seal Ball Valve
- High Performance Butterfly Valve

Irrigation

- Solenoid Control Valve
- Pressure Reducing Valve
- Pressure Relief Valve
- Diaphragm Valve
- Butterfly Valve
- Gate Valve

Water Treatment

- Flanged Butterfly Valve
- Knife Gate Valve
- Check Valve

INDEX

Product Type	Figure	Pager
Basic Valves	500 Series	1
Pressure Reducing Valves	PR500	4
Pressure Relief Valves	RS500	5
Float Valves	FM500	6
Non-Slam Check Valves	NC500	7
Solenoid Control Valves	SL500	8
Pump Control Valves	PF500	9
Multi-Funtion Valves	MF500	10
Basic Valves	300 Series	11
Pressure Reducing Valves	PR300	13
Pressure Relief Valves	RS300	14
Float Valves	FM300	15
Non-Slam Check Valves	NC300	16
Solenoid Control Valves	SL300	17
Differential Pressure Relief	DR300	18
Pressure Reducing Valves	PR300S	19
Pressure Relief Valves	RS300S	20
Float Valves	FM300S	21
Backflow Prevention Device	500X	22
Suction Diffuser	SD230	23
Pulsation Damper	PD607	25
Pressure Relief Valves	RS1050	28
Accessories		29
Conversion Tables		31

Water Control Valve Figure Number System

Type	Style	Material	Standard	Pressure
PR – Pressure Reducing Valve	500 – Y Type	D – Ductile Iron	1 – ANSI B16.1/B16.5	0 – Class 125/ 150
RS – Pressure Relief Valve	300 – Exquisite Type	S – Stainless Steel	2 – ISO 7005	1 – Class 250/ 300
FM – Float Valve		W – Carbon Steel	3 – BSEN 1092	2 – PN10 (150PSI)
NC – Non-Slam Check Valve			4 – DIN 2501	3 – PN16 (235PSI)
SL – Solenoid Valve			5 – JIS B2212/B2213	4 – PN25 (350PSI)
PF – Pump Control Valve				
DR – Pressure Differential Relief Valve				
MF – Multi-Function Valve				

* The valves designed and manufactured by Taloar provide ideal and correct solutions in the recommended application fields at the lowest purchasing price and maintenance cost, able to meet and even exceed the specified standards. Our certified standards are developed through years of experienced research and laboratory testing.

Easy Maintenance

Independent air chamber assembly can separately remove from the body, without removing the entire valve.

25% "Half-Through" Design

Y-type body design enables the valve to have excellent hydrodynamic functions.

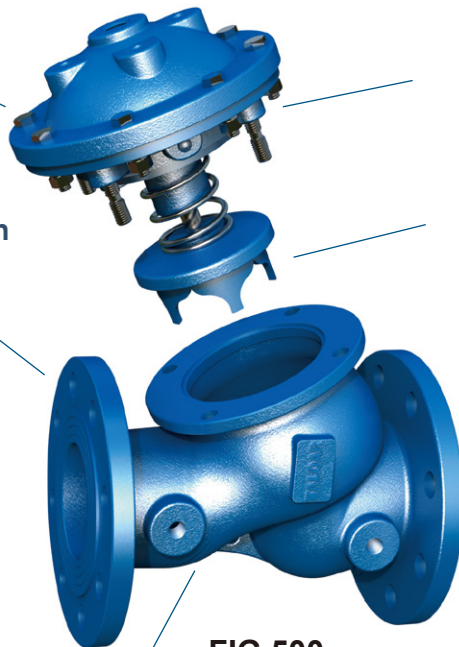

FIG. 500

Shell Painting

Inside and outside epoxy resin painting process offers better shell protection

Excellent Control Performance

Double-chamber diaphragm type control enables the valve to have excellent control performance, making the valve smooth in movement to eliminate impact and avoid damage that may be caused by water hammer

V-Type Intercepting Plug

The optional V-type intercepting plug is more suitable for low flow and high pressure differential applications to reduce vibration effectively

Large Flow

The fluid resistance is small, and the Cv value is greater than that of the ball ball-type control valve

Closed State

When the pressure at the inlet of the valve enters the air chamber, the basic valve will automatically close.

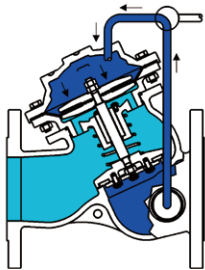

Opened State

Once the fluid in the air chamber is drained, the air chamber will not be able to store the pressure, and hence the basic valve will automatically open to allow the fluid to pass through.

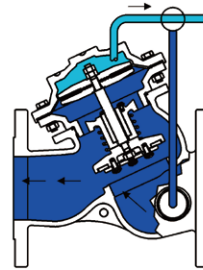

Control State

In case the corresponding control device is installed, the valve will automatically act according to the pressure in the pipeline to ensure the inlet/outlet pressure and flow of the valve.

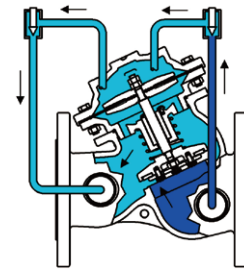

>> Product Features

- Reliable sealing performance
- Easy maintenance: Maintenance can be done without removing the body from the pipelines
- Different pivot valve combinations offer multiple functional control valves.
- Sensitive regulating and reliable performance
- Small fluid resistance and large flow
- Various connecting ends available
- Not easily blocked

Y-type basic valve is the basis of all water control valves, can equipped with different control devices to suit different applications, such as pressure reducing valves, pressure relief valves, solenoid valves, float valves, non-slam check valves, pump control valves, etc. The valves available in various sizes and connecting ends, are widely used in municipal water supply, building water supply, HVAC, fire protection, industrial use water, electricity and irrigation.

Material Specifications

Body/Bonnet: Ductile Iron/Stainless Steel
Trim: Stainless Steel/Bronze

End

DN50 mm Threaded, DN50 mm~DN500 mm Flange

Flange Standards

ANSI B16.1/B16.5
EN1092-2(BS 4504)/ISO 7005-2/DIN 2501

Working Pressure Range

175PSI, 235PSI, 350PSI
10Bar, 16Bar, 25Bar

Temperature/Medium

0°C~100°C normal temperature water (any applications in other special occasions must be clearly specified before ordering)

>> Size / Weight

Size (mm)	50T	50	65	80	100	125	150	200	250	300	350	400	500
L (mm)	184	205	229	250	320	370	415	500	605	725	733	990	1100
H (mm)	160	238	249	305	380	410	500	580	720	820	843	1095	1320
Weight	Lbs	13	24	29	49	82	101	165	276	478	816	838	2293
	kg	6	11	13	22	37	46	75	125	217	370	380	1040
Recommended max. flow (m ³ /h)	Continuous	47	55	68	104	182	324	409	704	1112	1589	1930	3880
	Peak	59	72	84	132	225	400	511	885	1396	1979	2347	4800

* When stainless steel body is selected, for DN100 mm valves, "L" is 326 mm, and for DN150 mm valves, "L" is 424mm, other dimensions remain unchanged.

* For valves size above DN500 mm, please contact factory.

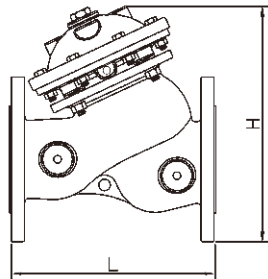

DN50mm~DN500mm
Flange

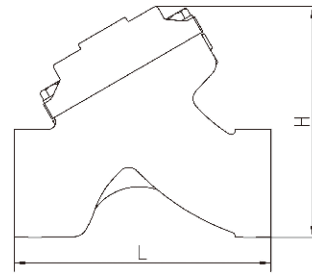

DN50mm
Thread

>> Flow Data

Size mm/In	Cv	Kv	Size mm/In	Cv	Kv
DN50 (2")	66	57	DN200 (8")	990	856
DN65 (2½")	100	86	DN250 (10")	1575	1362
DN80 (3")	140	121	DN300 (12")	2290	1980
DN100 (4")	240	205	DN350 (14")	3060	2646
DN125 (5")	460	397	DN400 (16")	4000	3460
DN150 (6")	590	510	DN500 (20")	5700	4930

Cv or Kv is $= \frac{Q}{\sqrt{\Delta P}}$. For a valve of a certain diameter, $Kv=Cv * 0.8649$, 1 kgf/cm²=14.22PSI, where Cv is the flow Q (GPM) when ΔP generated by 60 °F water passing through the valve is 1 PSI, and Kv is the flow Q (m³/h) when ΔP generated by 15°C water passing through the valve is 1 Bar.

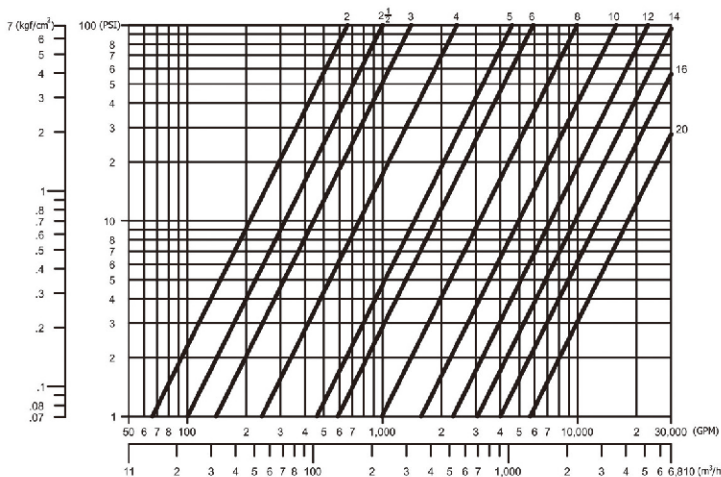

Pressure Differential – Without V-Type Intercepting Plug

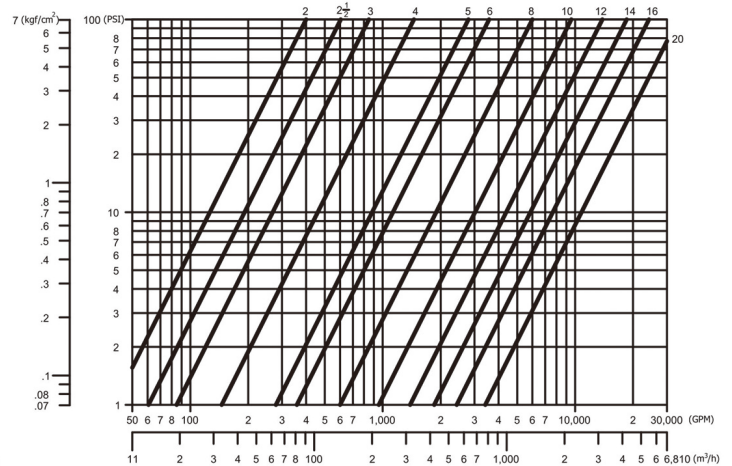

*Pressure Differential – With V-Type Intercepting Plug

» Valve Selection Steps

1. Determine the flow: In this example, your system demand flow is set as 800 GPM (182 m³/h).
2. Determine the pressure differential: Calculate the pressure differential between the inlet and outlet of the valve. In this example, your system requires that after the fluid passes through the valve, the pressure should drop by 4 PSI (0.28 kgf/cm²).
3. Calculate the Cv or Kv: In this example, $Cv = \frac{Q}{\sqrt{\Delta P}} = \frac{800}{\sqrt{4}} = 400$ OR $Kv = \frac{Q}{\sqrt{\Delta P}} = \frac{182}{\sqrt{0.28}} = 344$.
4. Determine the valve diameter: Find the valve whose Cv or Kv value is greater than the Cv or Kv value calculated by you from the Flow coefficient table according to the Cv or Kv value you calculated; Generally, the Cv or Kv value of the selected valve should be about 1.4 times the Cv or Kv value you calculated. From the table, it is determined that the Cv value of DN150 mm (6") valve is 590, meeting the demand.
5. Calculate the fluid velocity: After the valve diameter is determined, the fluid velocity can be calculated. In this example, the fluid velocity is 9.4FPS (2.86m/s).
6. Select the valve: The velocity of fluid passing through the valve varies with different applications. Generally, in pressure relief applications, fluid velocity is high. The corresponding valve size should be smaller accordingly to calculation. In this example, the DN125 mm (5") valve should be selected, and if you choose a valve for regulating purposes such as pressure reducing valves, the fluid velocity is recommended to be within the range indicated by the shaded part of the diagram of this page. In this example, DN150 mm (6") valve is recommended; however, if the V-type intercepting plug is selected, DN200 mm (8") valve is selected. For valves such as solenoid valves that act as switching, the fluid velocity should be lower than 6.5 FPS (2 m/s). For example, the DN200 mm (8") control valve should be selected.

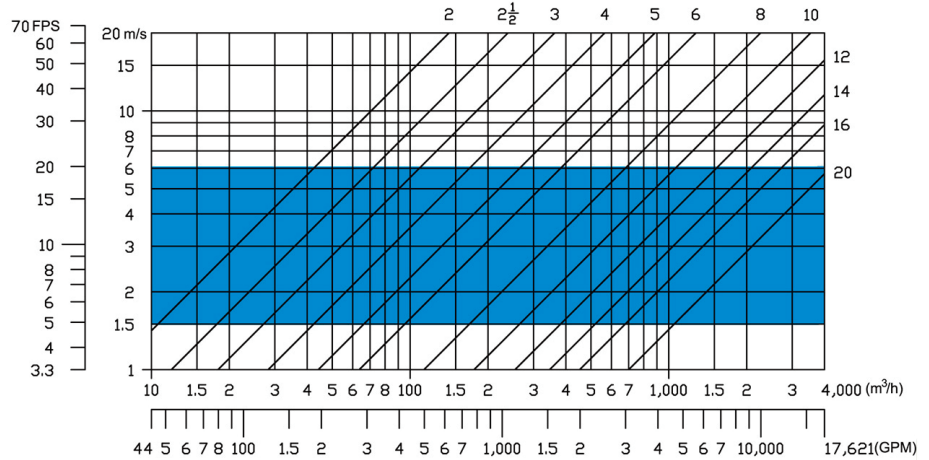

Pressure Loss Curve

» Solution to Pitting

● About Pitting

1. When a control valve is used as pressure reducing valve or pressure relief valve, pitting may be caused due to excessively large pressure differential between the two ends of the valve.
2. When the fluid passes through the valve bonnet at high velocity, the pressure will drop. When the pressure drops to the saturated vapor pressure of the fluid, the fluid will vaporize to form bubbles in the fluid. When these bubbles pass through the valve at a high speed, they will cut the valve parts and such damage is no less than damage that caused by impurities such as sediment. Besides, pitting also generates noise and vibration.

● Methods to Prevent Pitting

1. If conditions permit, increase the downstream pressure.
2. Select a valve with a larger diameter to reduce the velocity of fluid passing through the valve.
3. Use multiple parallel valves to reduce the flow passing through a single valve, reduce inlet pressure of the valve.
4. For pressure reducing valves, use multiple series valves to reduce the pressure differential across a single valve.

● Application Methods

1. Determine the upstream pressure of the valve, such as 147 PSI (10.3 kgf/cm²) as shown in the diagram.
2. Find the corresponding inlet pressure value and draw a horizontal straight line to pass through the shaded area to determine the intersection point of this straight line and the boundary line of the shaded area.
3. Determine the outlet pressure value at the intersection point, such as 37 PSI (2.6 kgf/cm²) as shown in the diagram.
4. Set the outlet pressure to a value equal to or greater than the outlet pressure value at the intersection point, such as 65 PSI (4.6 kgf/cm²) as shown in the diagram.

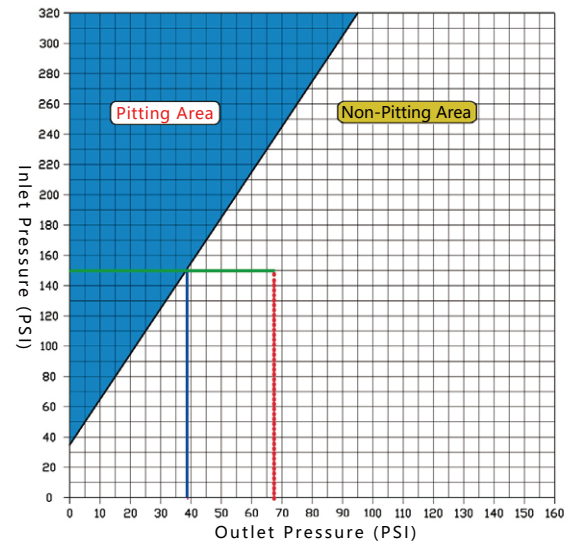

Product Features

- Sensitive and precise pressure control
- Easy regulating and maintenance
- Excellent and reliable sealing performance
- Built-in strainer, to prevent piping system from blocking

PR500 pressure reducing valve can automatically reduce high pressure at the inlet to a stable low pressure at the outlet regardless of changes in fluid velocity or inlet pressure, maintain outlet pressure within the preset range by a precise pressure regulator. When outlet pressure exceeds the set range of the pressure reducing valve, the basic valve body and the pressure regulator will automatically close to form a tight seal.

If the optional check feature is selected, when the back pressure generated, the return fluid will enter the air chamber to close the valve to prevent the fluid from back flow.



PR500

Material Specifications

Body/Bonnet: Ductile Iron/Stainless Steel
Disc & Stem: Stainless Steel
Piping: Bronze/Stainless Steel/Rubber Hose
Diaphragm: NBR
Fasteners and Springs: Stainless Steel

Working Pressure Range

175PSI/235PSI/350PSI
 10Bar/16Bar/25Bar

Flange Standards

ANSI / BSEN / ISO / DIN

Temperature/Medium

0°C~100°C normal temperature water

Pressure Regulator Parameters

Pressure Regulating Range: 0.1~5 kgf/cm²,
 5~9 kgf/cm², 7~17 kgf/cm²

Pressure Regulator Material: Stainless Steel

Please Provide the Following Data When Ordering

Valve figure number/size/pressure grade/
 connecting end type/pressure regulating
 range/other optional accessories

* Note: In valve installation, it is strongly suggested that sufficient space should be left for easy maintenance in the future. A strainer shall be mounted in front of the valve to prevent foreign matters from blocking the valve.

List of Accessories

- ① Strainer
- ② Ball Valve
- ③ Check Valve (Optional)
- ④ Needle Type Regulating Valve
- ⑤ Ball Valve
- ⑥ Pressure Regulator
- ⑦ Check Valve (Optional)
- ⑧ Ball Valve

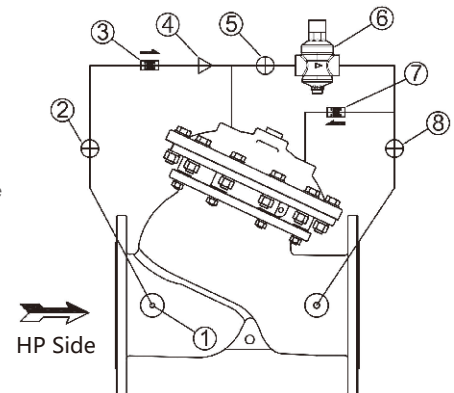

Piping Diagram

Typical Applications

If variable and large flow range demands, use multiple PR500 pressure reducing valves in parallel. In case of large flow demand, use two pressure reducing valves simultaneously. In case of small flow demand, the large-sized valve will automatically close, while the small-sized valve will continue to provide the required flow. When setting the pressure regulating range for the valves, the set pressure of the small-sized valve should be about 0.3 kgf/cm² higher than that of the large-sized valve. If the pressure reduction range is large, use multiple PR500 pressure reducing valves in series for sectional pressure reduction.

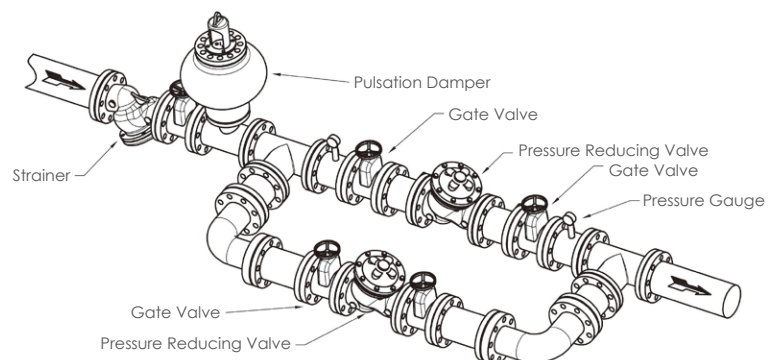

Product Features

- Precise pressure control
- Optional check feature
- Fast opening, to guarantee pipeline pressure
- Non-slam design, to prevent fluid impact
- Excellent and reliable sealing performance
- Built-in strainer, to prevent the piping system from blocking

RS500 pressure relief valve/pressure holding/back pressure valve is a fluid controlled valve. It can maintain pressure of the upstream pipe by regulating the diaphragm of the pressure regulator. The valve can be used in pressure relief, pressure holding and back pressure impact occasions.

During operation, the valve senses inlet pressure of the valve by the pressure regulator to control the valve to open or to close. When inlet pressure exceeds the set value, the valve will open quickly to maintain pressure in the pipelines. After pressure release, the valve will close slowly to prevent water hammer impact. If the optional check feature is selected, when the back pressure is generated, the return fluid will enter the air chamber to close the valve to prevent the fluid from back flow.

Material Specifications

Body/Bonnet: Ductile Iron/Stainless Steel
Disc & Stem: Stainless Steel
Piping: Bronze/Stainless Steel/Rubber Hose
Diaphragm: NBR
Fasteners and Springs: Stainless steel

Working Pressure Range

175PSI/235PSI/350PSI
 10Bar/16Bar/25Bar

Flange Standards

ANSI / BSEN / ISO / DIN

Temperature/Medium

0°C~100°C normal temperature water

Pressure Regulator Parameters

Pressure Regulating Range: 0.1~5 kgf/cm²,
 2~9 kgf/cm², 7~17 kgf/cm²

Pressure Regulator Material: Stainless Steel

Please Provide the Following Data When Ordering

Valve figure number/size/pressure grade/
 connecting end type/pressure regulating
 range/other optional accessories

* Note: In valve installation, it is strongly suggested that sufficient space should be left for easy maintenance in the future. A strainer shall be mounted in front of the valve to prevent foreign matters from blocking the valve.



RS500

List of Accessories

- ① Strainer
- ② Ball Valve
- ③ Check Valve (Optional)
- ④ Needle Type Regulating Valve
- ⑤ Ball Valve
- ⑥ Pressure Regulator
- ⑦ Check Valve (Optional)
- ⑧ Ball Valve

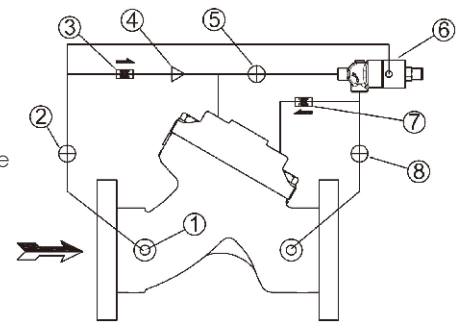

Piping Diagram

Typical Applications

● As a Pressure Relief Valve

To prevent high-pressure impact generated during pump shutdown, the quick opening and slow closing of the pressure relief valve can be used to release excess high pressure to protect the system.

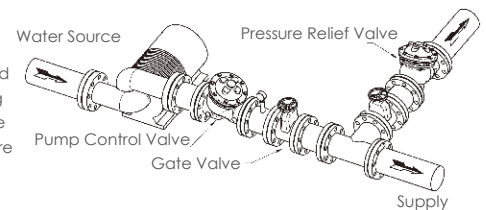

● As a Pressure Holding Valve

When the valve is installed between the high-pressure supply at upstream and large-flow demand at downstream, it can be used as a pressure holding valve to maintain high pressure at upstream, also to prevent continuous pressure dropping in the main pipe due to excessive flow demand at downstream to maintain pressure in the main pipe.

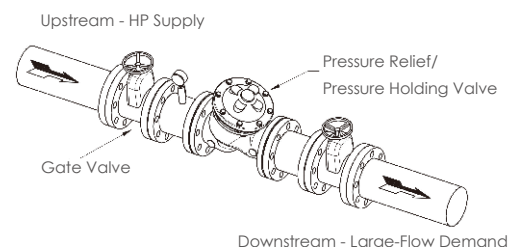

Product Features

- Precise and repeatable water level control
- Ideal slow opening and closing functions
- Reliable full hydraulic control
- Reliable tightness
- Large flow
- Built-in strainer, to prevent the piping system blocking

FM500 diaphragm float valve is a fluid controlled valve. It keeps the water level in the storage tank at a relatively stable level. The float control switch is installed in the water tank when the water level is high and is connected to the basic valve through the pipeline. When the water level rises and exceeds the maximum limited level, the float pilot valve will fully close and the basic valve automatically closed. When the water level drops to the lowest limited level, the float pilot valve will be fully open, the basic valve will automatically open for water supplement until the level in the water storage tank is controlled within the stable ideal range.

If the optional check feature is selected, when the back pressure is generated, the return fluid will enter the air chamber to close the valve to prevent the fluid from back flow.



FM500

Material Specifications

Body/Bonnet: Ductile Iron/Stainless Steel
Disc & Stem: Stainless Steel
Piping: Bronze/stainless Steel/Rubber Hose
Diaphragm: NBR
Fasteners and Springs: Stainless Steel

Working Pressure Range

175PSI/235PSI/350PSI
 10Bar/16Bar/25Bar

Flange Standards

ANSI / BSEN / ISO / DIN

Temperature/Medium

0°C~100°C normal temperature water

Float Switch Parameters

Controller: ½" float valve
Pressure Regulator Material: Brass/Stainless Steel

Please Provide the Following Data When Ordering

Valve figure number/size/pressure grade/ connecting end type/other optional accessories

* Note: In valve installation, it is strongly suggested that sufficient space should be left for easy maintenance in the future. A strainer shall be mounted in front of the valve to prevent foreign matters from blocking the valve.

List of Accessories

- ① Strainer
- ② Ball Valve
- ③ Check Valve (Optional)
- ④ Needle Type Regulating Valve
- ⑤ Needle Type Regulating Valve
- ⑥ Check Valve (Optional)
- ⑦ Ball Valve (Optional)

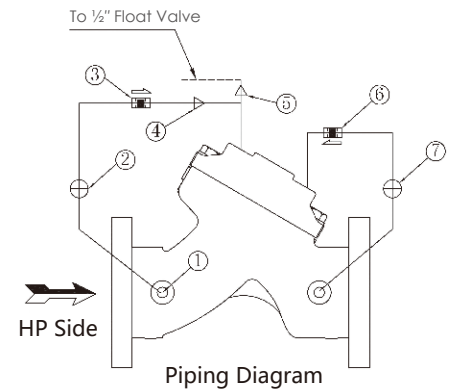

Typical Applications

Install the valve and float control switch as shown in the diagram. The float control switch should be installed on the relative static water surface at the outlet of the connected pipeline and positioned at the desired water level.

The outlet should be as far away from the float controller as possible (recommended: >5 m), otherwise, the level fluctuation generated by the water outlet may cause frequent valve opening and closing, generate noise and thus shorten the service life of the valve.

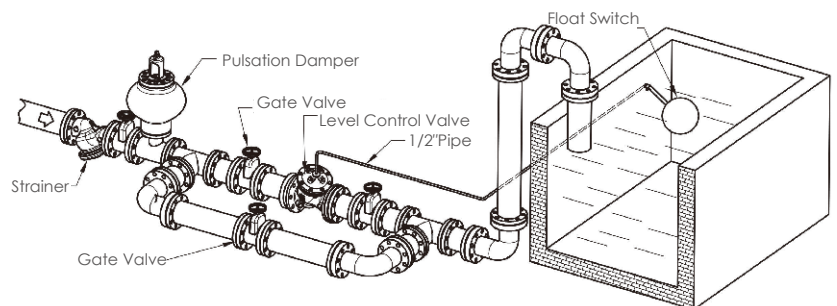

Product Features

- Smooth action, without impact
- Easy regulating and maintenance
- Excellent and reliable sealing performance
- Controllable opening and closing speed
- Built-in strainer, to prevent the piping system from blocking

NC500 silencing non-slam check valve is a hydraulically controlled diaphragm valve with controllable opening and closing speed. When inlet pressure rises and exceeds the valve opening pressure, the valve will open slowly to avoid impact. When the back pressure is generated, the fluid will enter the air chamber of the valve, and the valve will close slowly to form a tight seal. The opening and closing speed can be adjusted by the opening angle of the needle valve in the main pipe.

The valve is particularly suitable for use in the occasions where absolute sealing is required. Its rubber seal ring can ensure that the valve is free from leakage. In addition, the simple design of the valve can also ensure reliability.



NC500

Material Specifications

Body/Bonnet: Ductile Iron/Stainless Steel
Disc & Stem: Stainless Steel
Piping: Bronze/Stainless Steel/Rubber Hose
Diaphragm: NBR
Fasteners and Springs: Stainless Steel

Working Pressure Range

175PSI/235PSI/350PSI
 10Bar/16Bar/25Bar

Flange Standards

ANSI / BSEN / ISO / DIN

Temperature/Medium

0°C~100°C normal temperature water

Please Provide the Following Data When Ordering

Valve figure number/size/pressure grade/
 connecting end type/other optional
 accessories

* Note: In valve installation, it is strongly suggested that sufficient space should be left for easy maintenance in the future. A strainer shall be mounted in front of the valve to prevent foreign matters from blocking the valve.

List of Accessories

- ① Strainer
- ② Ball Valve
- ③ Check Valve (Optional)
- ④ Needle Type Regulating Valve
- ⑤ Ball Valve
- ⑥ Check Valve (Optional)
- ⑦ Needle Type Regulating Valve

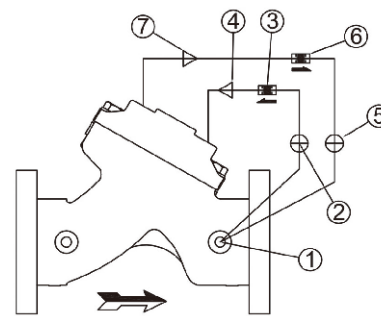

Piping Diagram

Typical Applications

● Deep Well Pump

In occasions where a deep well pump is required in design, the non-slam check valve should be installed. When the pump is shut down or sudden powered off, the non-slam check valve will close slowly to avoid the damaging water hammer caused by rapid back flow of fluid.

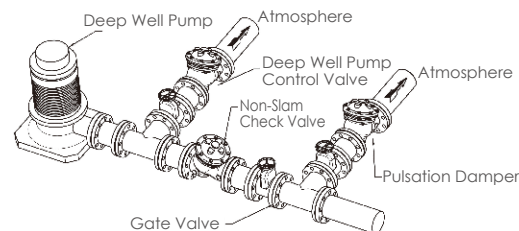

● Booster Pump

Install NC500 non-slam check valve at the outlet of booster pump can prevent fluid from entering the water storage tank when the pump is shut down. The pressure relief valve shown in the diagram can effectively prevent the impact occurring during pump shutdown.

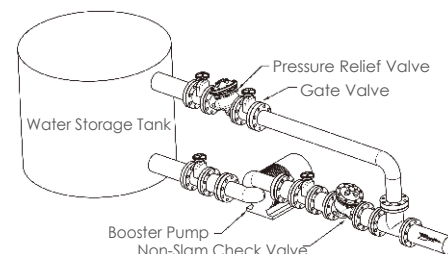

Product Features

- Sensitive and rapid action
- Easy regulating and maintenance
- Excellent and reliable sealing performance
- Built-in strainer, to prevent the piping system from blocking
- Optional check feature

SL500 solenoid control valve mainly controls opening and closing of the valve by receiving the opening or closing signal through the solenoid valve. It consists of a basic valve and an electromagnetic switch. The electromagnetic switch controls the liquid in the air chamber to control the valve to open or to close.

The standard opening and closing speed control valve can independently control the opening and closing speeds of the valve to avoid the water hammer and vibration common in solenoid valves.

If the optional check feature is selected, when the back pressure is generated, the return fluid will enter the air chamber to close the valve to prevent the fluid from back flow.



SL500

Material Specifications

Body/Bonnet: Ductile Iron/Stainless Steel
Disc & Stem: Stainless Steel
Piping: Bronze/Stainless Steel/Rubber Hose
Diaphragm: NBR
Fasteners and Springs: Stainless Steel

Working Pressure Range

175PSI/235PSI/350PSI
 10Bar/16Bar/25Bar

Flange Standards

ANSI / BSEN / ISO / DIN

Temperature/Medium

0°C~100°C normal temperature water

Solenoid Valve Parameters

Voltage Range: 110 V, 50~60 Hz, AC or 220 V, 50~60 Hz, AC
State: NC (normally closed) or NO (normally open) (please specify the specific state while ordering)
Body Material: Brass/stainless steel

Please Provide the Following Data When Ordering

Valve figure number/size/pressure grade/connecting end type/voltage range/NC or NO/other optional accessories

* Note: In valve installation, it is strongly suggested that sufficient space should be left for easy maintenance in the future. A strainer shall be mounted in front of the valve to prevent foreign matters from blocking the valve.

List of Accessories

- ① Strainer
- ② Ball valve
- ③ Check Valve (Optional)
- ④ Needle Type Regulating Valve
- ⑤ Needle Type Regulating Valve
- ⑥ Electromagnetic Switch
- ⑦ Check Valve (Optional)
- ⑧ Ball Valve

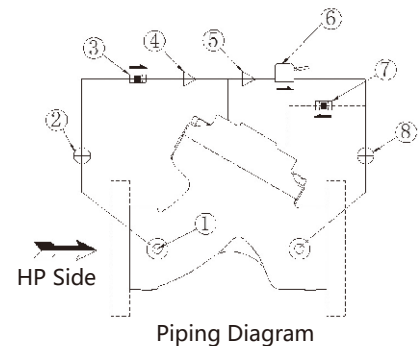

Typical Applications

SL500 solenoid control valve is applicable to many situations in the industry, such as mixing, cleaning, stirring and other occasions that require switching control. The switching signal can direct control signal or the signal generated by the sensor to control the valve to open or to close. The solenoid control valve can be used to control water level. The sensor installed on the water storage tank generates the switching signal to control the opening and closing of solenoid control valve, so as to control water level.

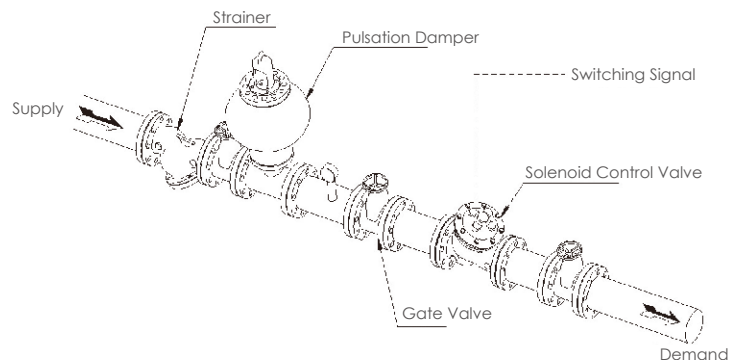

Product Features

- Separately controllable opening and closing speed
- Manual operated electromagnetic control switch available.
- Excellent and reliable sealing performance
- Easy operation and maintenance
- Built-in strainer, to prevent the guide piping system from blocking

The pump control valve is installed at the pump outlet, controlled by the guide pipe to eliminate the impact of the fluid on the pipelines during pump start-up or power-off.

At pump start-up, the control valve is in closed state. After the start-up, the electromagnetic control switch is powered on; the valve will open gradually; the pressure in the pipeline rises slowly until the working head of the pump is reached.

When the pump receives the shutdown signal, the electromagnetic control switch will power off; the valve will start to close gradually; the flow in the pipeline gradually reduces while the water pump is still working. When the valve is fully closed, the limit switch installed on the valve will form an electronic interlocking relationship with the pump to cancel the pump start-up command, the pump stops.

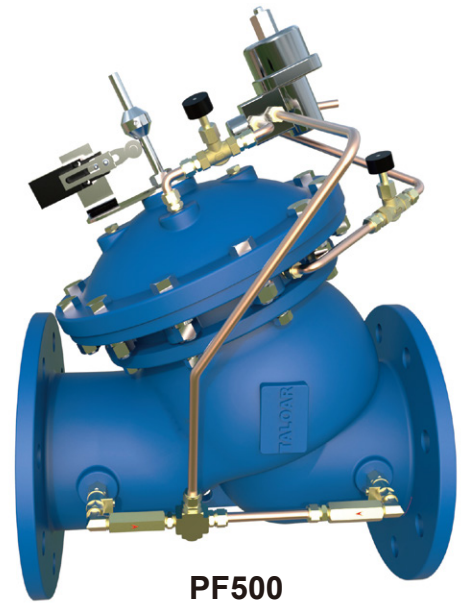

PF500

Material Specifications

Body/Bonnet: Ductile Iron/Stainless Steel
Disc & Stem: Stainless Steel
Piping: Bronze/Stainless Steel/Rubber Hose
Diaphragm: NBR
Fasteners and Springs: Stainless Steel

Working Pressure Range

175PSI/235PSI/350PSI
 10Bar/16Bar/25Bar

Flange Standards

ANSI / BSEN / ISO / DIN

Temperature/Medium

0°C~100°C normal temperature water

Solenoid Valve Parameters

Voltage Range: 110 V, 50~60 Hz,
 AC or 220 V, 50-60Hz, AC
Body Material: Brass/Stainless Steel

Please Provide the Following Data When Ordering

Valve figure number/size/pressure grade/
 connecting end type/voltage range/other
 optional accessories

* Note: In valve installation, it is strongly suggested that sufficient space should be left for easy maintenance in the future. A strainer shall be mounted in front of the valve to prevent foreign matters from blocking the valve.

List of Accessories

- ① Strainer
- ② Strainer
- ③ Ball Valve
- ④ Ball Valve
- ⑤ Check Valve
- ⑥ Check Valve
- ⑦ Three-Way Pilot Valve
- ⑧ Needle Type Regulating Valve
- ⑨ Needle Type Regulating Valve
- ⑩ Limit Switch
- ⑪ Electromagnetic Control Switch

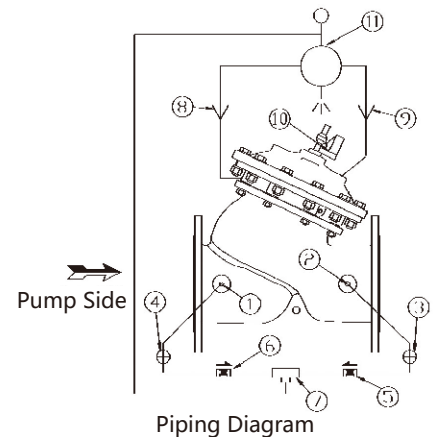

Piping Diagram

Typical Applications

The installation of PF500 pump control valve is as shown in the diagram. The control circuits of the electromagnetic control switch and the limit switch must be sealed with flexible conduits.

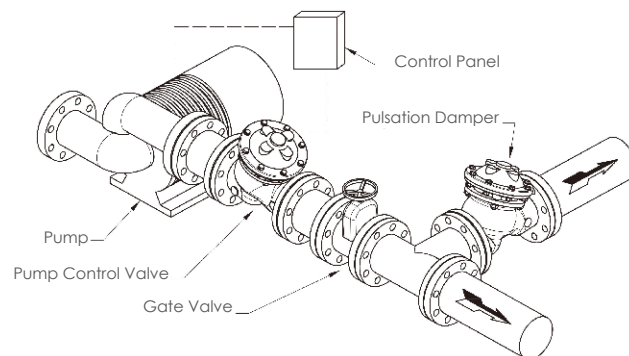

Product Features

- Position indicator
- No lubrication required
- Reserved connections for testing
- Removable top cap design, making the pipeline repair easy
- Horizontal or vertical installation
- O-ring seal, zero leakage
- Multiple functions, saving purchasing cost

The multi-functional valve can perform more functions on the same valve body. First, it can be used as silencing check valve or on-off valve. Apart from that, it can also be a balance valve. Besides, it has two connections points reserved for testing.

A unique V-shaped seat is used in the valve therefore the valve has good regulating performance. Due to the design features, the valve can be maintained in the pipelines without special tools, without the need for removing the valve from the pipeline.

The multi-function valve integrates the functions of butterfly valve, balance valve, silencing check valve and measuring valve. The use of the multi-functional valve can shorten installation time, reduce installation space, and save installation cost (including hardware cost, labor cost, etc.).

Material Specifications

Body/Bonnet: Ductile Iron/Stainless Steel

Disc & Stem: Stainless Steel

Fasteners and Springs: Stainless Steel

Working Pressure Range

175PSI/235PSI/350PSI

10Bar/16Bar/25Bar

Flange Standards

ANSI / BSEN / ISO / DIN

Temperature/Medium

0°C~100°C normal temperature water

Please Provide the Following Data When Ordering

Valve figure number/size/pressure grade/ connecting end type/other optional accessories

Pressure Loss Curve

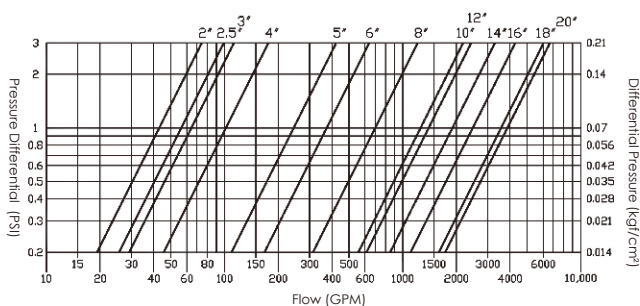

MF500

Overall Dimensions

Size mm/In	A(mm)	B(mm)	Weight	
			Lbs	kg
DN50 (2"Tr)	184	173	13	6
DN50 (2")	205	236	24	11
DN65 (2.5")	229	240	33	15
DN80 (3")	250	240	53	24
DN100 (4")	320	310	95	43
DN125 (5")	370	340	137	62
DN150 (6")	415	370	187	85
DN200 (8")	500	530	331	150
DN250 (10")	605	610	485	220
DN300 (12")	725	665	816	370
DN350 (14")	733	715	849	385
DN400 (16")	990	970	992	450
DN450 (18")	1000	1125	1213	550
DN500 (20")	1100	1111	1499	680

1. Connection for testing: 1/4" threads

2. If you have special demands, please contact the factory for more details.

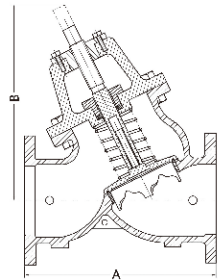

Typical Applications

1. Butterfly Valve
2. Y-Type Strainer
3. Bend
4. Suction Stabilizer
5. Diffuser
6. Multi-Function Valve

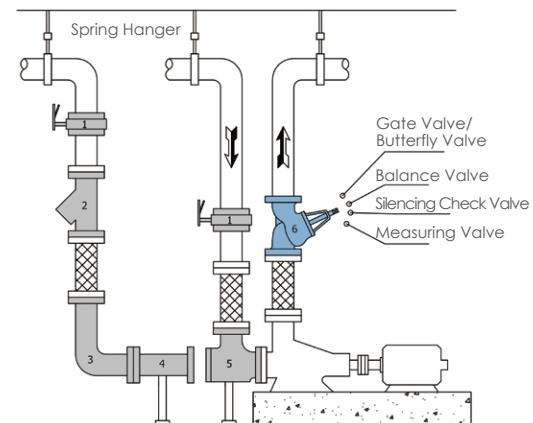

Product Features

- Simple structure for easy repair and maintenance
- Strong flow capacity and small head loss
- Excellent and reliable sealing performance
- Integrate with different pilot sub-valves to form various water functional control valves
- Multiple body and diaphragm materials available for selection to suit various medium environments

TALOAR lightweight basic valve is designed as a hydraulic diaphragm direct sealing control valve. It can be equipped with different pilot sub-valves to form water functional valves for various functions, such as pressure reducing valve, float valve, pressure relief valve, pressure differential relief valve, non-slam check valve, solenoid control valve, etc., which are widely used in the facilities for municipal water supply, building water supply, HVAC, fire protection, industrial use water, electricity and irrigation.

This lightweight water control valve is simple in structure. Inside the body, diaphragm is the only moving part. The valve can be repaired or maintained in the pipelines, without removing the entire valve from the pipeline after the top cap is removed, and the internal structures of the valve can be seen!

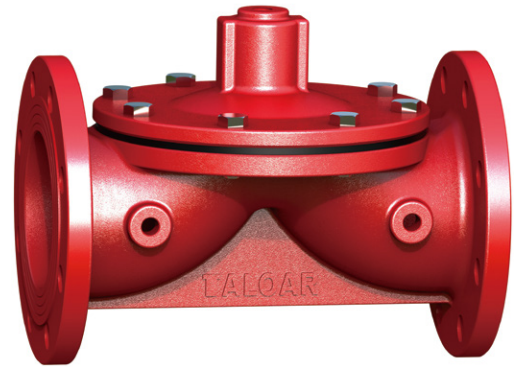
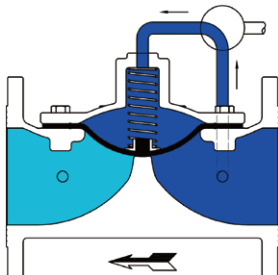

FIG.300

Closed State

When the pressure at the inlet of the valve enters the air chamber, the basic valve will automatically close.



Opened State

Once the fluid in the air chamber is drained, the air chamber will not be able to store the pressure. Hence the basic valve will automatically open to allow the fluid to pass through.

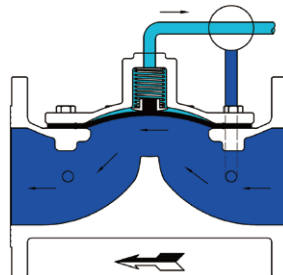

Control State

In the case that the corresponding control device is installed, the valve will automatically act according to the pressure in the pipeline to ensure the inlet/outlet pressure and flow of the valve.

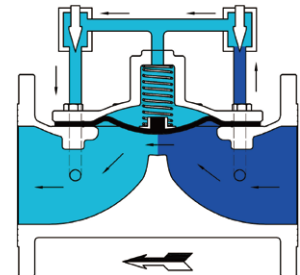

Material Specifications

Body/Bonnet: Ductile Iron/Stainless Steel

Trim: Stainless Steel/Brass

Diaphragm: EPDM

End

DN50 mm~DN300 mm flanges

Flange Standards

ANSI B16.1/B16.5

EN1092-2(BS4504)/ISO7005-2/DIN2501

Working Pressure Range

175PSI, 235PSI

10Bar, 16Bar

Temperature/Medium

0°C~100°C normal temperature water

(for any other special applications, must clearly specified before ordering)

Size/Weight

Size mm	50	65	80	100	125	150	200	250	300
L (mm)	200	220	285	307	370	390	500	605	650
H (mm)	195	200	220	242	280	315	400	460	500
Weight	Lbs	19	20	35	40	82	106	183	298
	kg	8.5	9	16	18	37	48	83	135

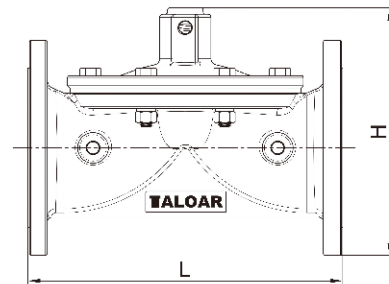

* For valves size above DN300 mm, please contact the factory.

» Flow Data/Curve

Size mm/In	Cv	Kv
DN50(2")	100.6	87
DN65(2½")	157.2	136
DN80(3")	185.0	160
DN100(4")	213.9	185
DN125(5")	398.9	345
DN150(6")	605.9	524
DN200(8")	919.2	795
DN250(10")	1479.9	1280
DN300(12")	2104.3	1820

Cv or Kv is $\frac{Q}{\sqrt{\Delta P}}$. For a valve of a certain diameter, $Kv=Cv \cdot 0.8649$, 1 kgf/cm²=14.22PSI, where Cv is the flow Q (GPM) when ΔP generated by 60 °F water passing through the valve is 1 PSI, and Kv is the flow Q (m³/h) when ΔP generated by 15°C water passing through the valve is 1 Bar.

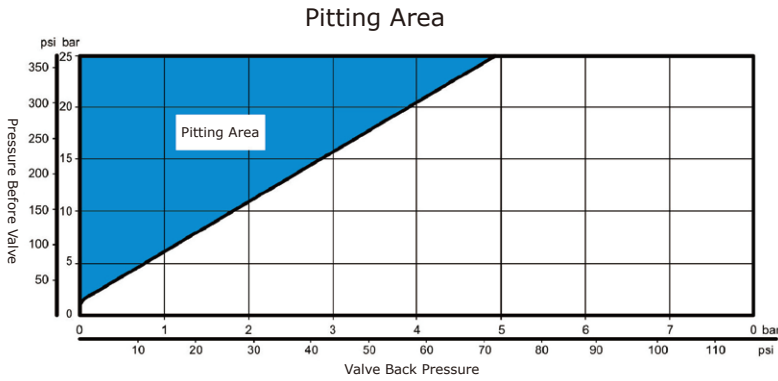
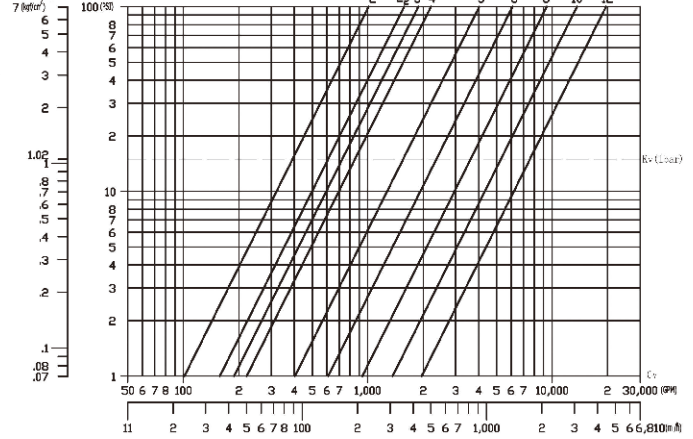

» Piping Diagrams of Water Control Valves

- ① Strainer ② Ball Valve
- ③ Needle Valve/Ball Valve
- ④ Ball Valve ⑤ Basic Valve

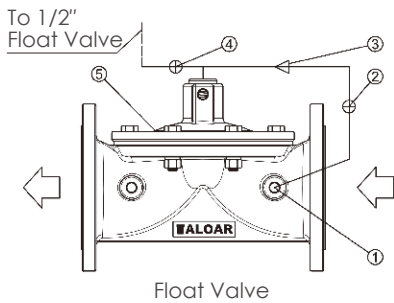

- ① Strainer ② Ball Valve
- ③ Needle Valve/Ball Valve
- ④ Ball Valve
- ⑤ Pressure Reducing Pilot Valve
- ⑥ Ball Valve ⑦ Basic Valve

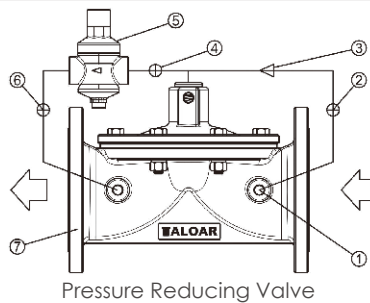

- ① Strainer ② Ball Valve
- ③ Needle Valve/Ball Valve
- ④ Ball Valve
- ⑤ Pressure Relief Pilot Valve
- ⑥ Ball Valve ⑦ Basic Valve

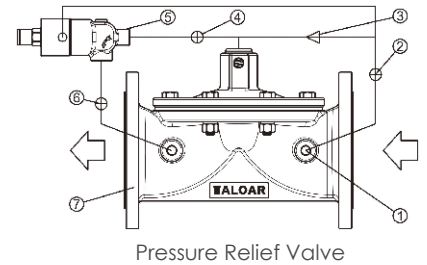

- ① Strainer ② Ball Valve
- ③ Check Valve
- ④ Needle Valve/Ball Valve
- ⑤ Ball Valve ⑥ Check Valve
- ⑦ Needle Valve ⑧ Basic Valve

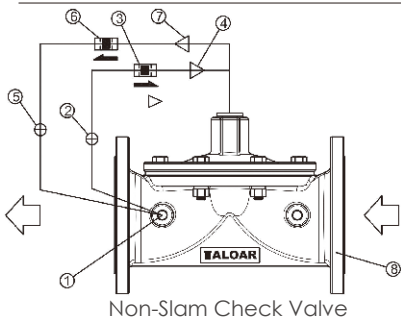

- ① Strainer ② Ball Valve
- ③ Needle Valve/Ball Valve
- ④ Ball Valve
- ⑤ Electromagnetic Switch
- ⑥ Ball Valve ⑦ Basic Valve

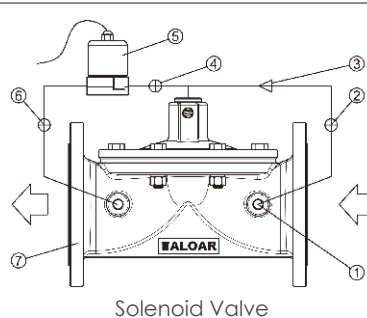

- ① Strainer ② Ball Valve
- ③ Needle Valve/Ball Valve
- ④ Ball Valve
- ⑤ Differential Pressure Pilot Valve
- ⑥ Ball Valve ⑦ Basic Valve

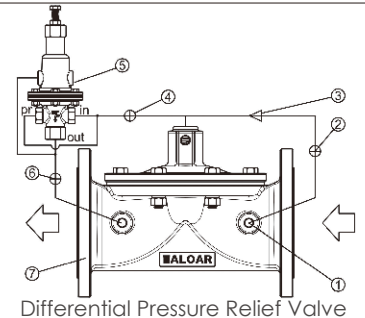

Product Features

- Sensitive and precise pressure control
- Small volume and light weight
- Easy regulating and maintenance
- Excellent sealing performance
- Built-in strainer, to prevent the guide piping system from being blocked

PR300 lightweight pressure reducing valve can automatically reduce high pressure at the inlet to a stable low pressure at outlet regardless of changes in fluid velocity or inlet pressure. Maintain outlet pressure within the preset range by a precise pressure regulator. When outlet pressure exceeds the set range of the pressure reducing valve, the basic valve body and the pressure regulator will automatically close to form a tight seal.

If the optional check feature is selected, when the back pressure is generated, the return fluid will enter the air chamber to close the valve to prevent the fluid from back flow.

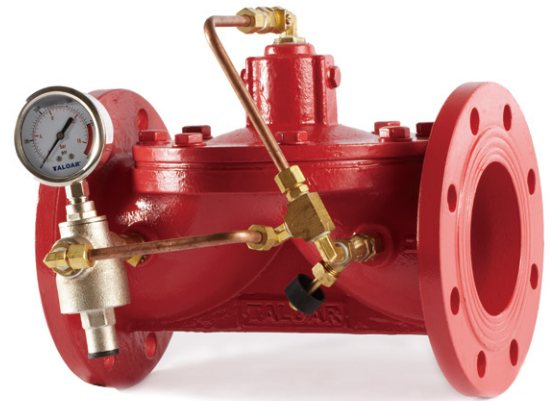

PR300

Material Specifications

Body/Bonnet: Ductile Iron/Stainless Steel
Disc & Stem: Stainless Steel
Piping: Bronze/Stainless Steel/Rubber Hose
Diaphragm: EPDM
Fasteners and Springs: Stainless Steel

Working Pressure Range

175PSI/235PSI
 10Bar/16Bar

Flange Standards

ANSI / BSEN / ISO / DIN

Temperature/Medium

0°C~100°C normal temperature water

Pressure Regulator Parameters

Pressure Regulating Range: 0.1~5 kgf/cm²,
 5~9 kgf/cm², 7~17 kgf/cm²
Pressure Regulator Material: Stainless Steel

Please Provide the Following Data When Ordering

Valve figure number/size/pressure grade/
 connecting end type/pressure regulating
 range/other optional accessories

* Note: In valve installation, it is strongly suggested that sufficient space should be left for easy maintenance in the future. A strainer shall be mounted in front of the valve to prevent foreign matters from blocking the valve.

List of Accessories

- ① Strainer (Built-In)
- ② Ball Valve
- ③ Needle Type Regulating Valve
- ④ Ball Valve
- ⑤ Pressure Reducing Valve
- ⑥ Ball Valve
- ⑦ Body

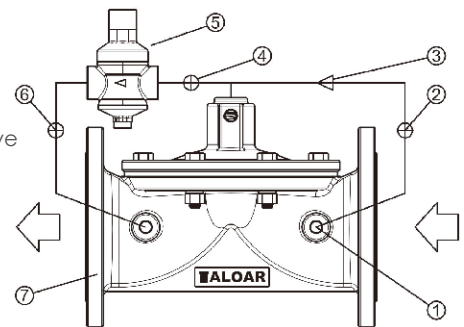

Piping Diagram

Typical Applications

If the flow demand varies in a large range, multiple PR300 pressure reducing valves should be used in parallel. In case of large flow demand, two pressure reducing valves should work simultaneously. In case of small flow demand, the large-size valve will automatically close, while the small-size valve will continue to provide the required flow. When setting the pressure regulating range for the valves, the set pressure of the small-size valve should be about 0.3 kgf/cm² higher than that of the large-size valve.

If the pressure reduction range is large, multiple PR300 pressure reducing valves should be used in series for sectional pressure reduction.

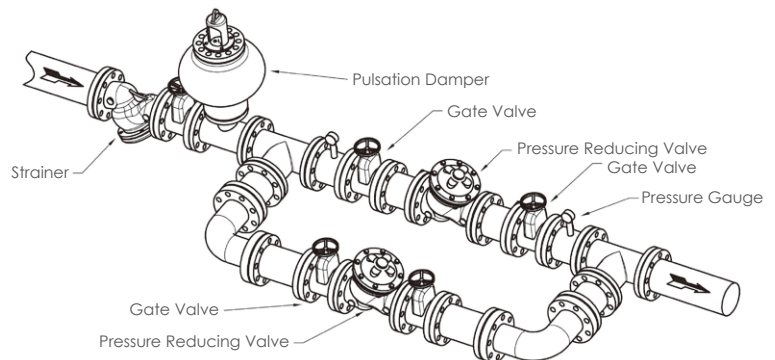

Product Features

- Precise pressure control
- Small volume and light weight
- Fast opening, to guarantee pipeline pressure
- Non-slam design, to prevent fluid impact
- Built-in strainer, to prevent the guide piping system from being blocked

RS300 lightweight pressure relief valve/pressure holding/back pressure valve is a hydraulic control valve controlled by a pressure regulator, can maintain pressure in upstream pipelines, can be used in pressure relief, pressure holding and back pressure impact situations. During operation, the valve senses inlet pressure of the valve by the pressure regulator to control valve opening or closing. When inlet pressure exceeds the set value, the valve will open quickly to maintain pressure in the pipelines. After pressure release, the valve will close slowly to prevent impact.

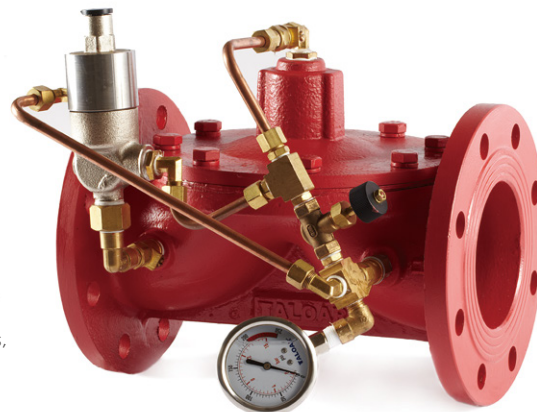

RS300

Material Specifications

Body/Bonnet: Ductile Iron/Stainless Steel
Disc & Stem: Stainless Steel
Piping: Bronze/Stainless Steel/Rubber Hose
Diaphragm: EPDM
Fasteners and Springs: Stainless Steel

Working Pressure Range

175PSI/235PSI
 10Bar/16Bar

Flange Standards

ANSI / BSEN / ISO / DIN

Temperature/Medium

0°C~100°C normal temperature water

Pressure Regulator Parameters

Pressure Regulating Range: 0.1~5 kgf/cm²,
 2~9 kgf/cm², 7~17 kgf/cm²

Pressure Regulator Material: Stainless Steel

Please Provide the Following Data When Ordering

Valve figure number/size/pressure grade/
 connecting end type/pressure regulating
 range/other optional accessories

* Note: In valve installation, it is strongly suggested that sufficient space should be left for easy maintenance in the future. A strainer shall be mounted in front of the valve to prevent foreign matters from blocking the valve.

List of Accessories

- ① Strainer
- ② Ball Valve
- ③ Needle Type Regulating Valve
- ④ Ball Valve
- ⑤ Pressure Relief Valve
- ⑥ Ball Valve
- ⑦ Body

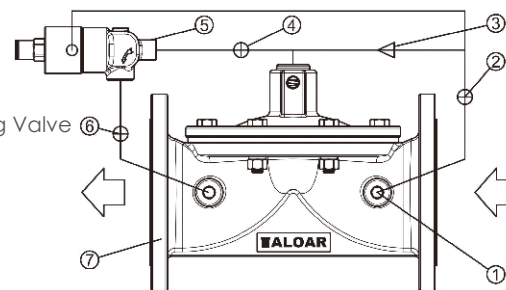

Piping Diagram

Typical Applications

● As a Pressure Relief Valve

To prevent high-pressure impact generated during pump shutdown, the quick opening and slow closing the pressure relief valve can be used to release excess high pressure to protect the system.

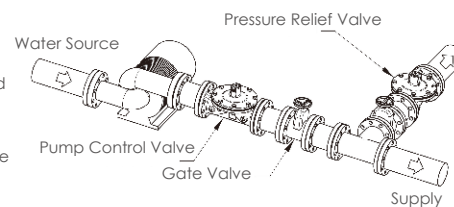

● As a Pressure Holding Valve

When the valve is installed between the high-pressure supply at upstream and large-flow demand at downstream, a pressure holding valve is used to maintain high pressure at upstream, so as to prevent pressure in the main pipe from dropping continuously due to excessive flow demand at downstream to maintain pressure in the main pipe.

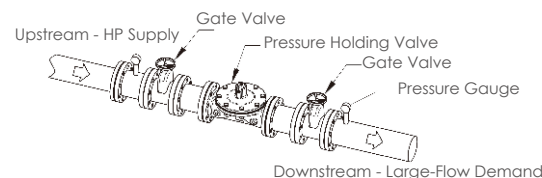

Product Features

- Precise and repeatable water level control
- Small volume and light weight
- Reliable full hydraulic control
- Reliable tightness
- Large flow
- Built-in strainer, to prevent the guide piping system from being blocked

FM300 diaphragm float valve is a hydraulic controlled valve. It keeps the water level in the storage tank at a relatively stable level. The float control switch is installed in the water tank when the water level is high and is connected to the basic valve through the pipeline. When the water level rises and exceeds the maximum limited level, the float pilot valve will fully close and the basic valve automatically closed. When the water level drops to the lowest limited level, the float pilot valve will be fully open, the basic valve will automatically open for water supplement until the level in the water storage tank is controlled within the stable ideal range.

If the optional check feature is selected, when the back pressure is generated, the return fluid will enter the air chamber to close the valve to prevent the fluid from back flow.

Material Specifications

Body/Bonnet: Ductile Iron/Stainless Steel
Disc & Stem: Stainless Steel
Piping: Bronze/Stainless Steel/Rubber Hose
Diaphragm: EPDM
Fasteners and Springs: Stainless Steel

Working Pressure Range

175PSI/235PSI
 10Bar/16Bar

Flange Standards

ANSI / BSEN / ISO / DIN

Temperature/Medium

0°C~100°C normal temperature water

Float Switch Parameters

Controller: 1/2" Float Valve
 (to be purchased separately)
Body Material: Brass/Stainless Steel

Please Provide the Following Data When Ordering

Valve figure number/size/pressure grade/
 connecting end type/other optional
 accessories

* Note: In valve installation, it is strongly suggested that sufficient space should be left for easy maintenance in the future. A strainer shall be mounted in front of the valve to prevent foreign matters from blocking the valve.

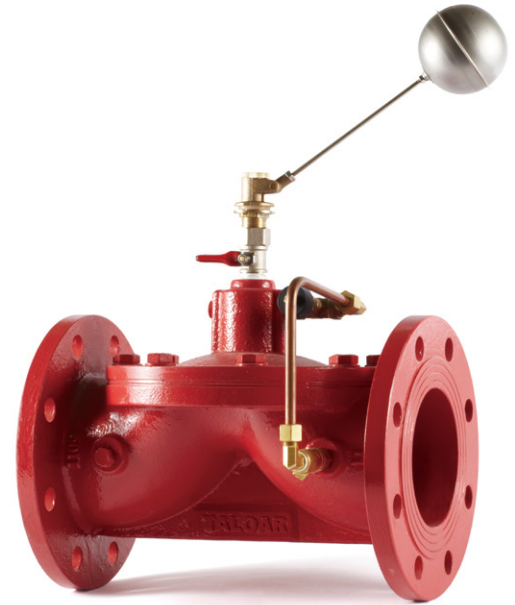

FM300

List of Accessories

- ① Strainer (Built-In)
- ② Ball Valve
- ③ Needle Type Regulating Valve
- ④ Ball Valve
- ⑤ Body

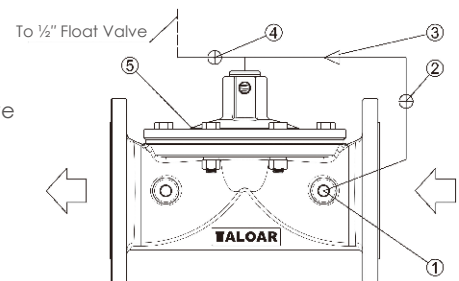

Piping Diagram

Typical Applications

Install the valve and float control switch as shown in the diagram. The float control switch should be installed on relative static water surface at the outlet of the connected pipeline and positioned at the desired water level.

The outlet should be as far away from the float controller as possible (recommended: >5 m). Otherwise, the level fluctuation generated by the water outlet may cause frequent valve opening and closing, to produce noise and thus shorten the service life of the valve.

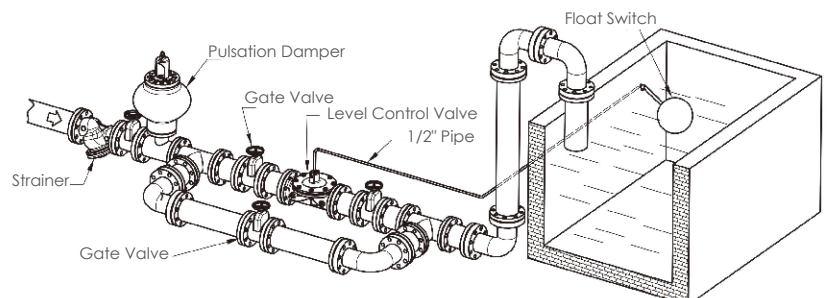

Product Features

- Smooth action, without impact
- Small volume and light weight
- Easy regulation and maintenance
- Excellent and reliable sealing performance
- Separately controllable opening and closing speed
- Built-in strainer, to prevent the guide piping system from being blocked

NC300 silencing non-slam check valve is a hydraulically controlled diaphragm control valve with controllable opening and closing speed. When inlet pressure rises and exceeds the valve opening pressure, the valve will open gradually to avoid impact. When the back pressure is generated, the fluid will enter the air chamber of the valve, and the valve will close gradually to form a tight seal. The opening and closing speed can be adjusted by the opening angle of the guide piping needle valve.

The valve is particularly suitable for use in the situations where absolute sealing is required. Its rubber seal ring can ensure that the valve is of no leakage. In addition, the simple design of the valve can also ensure its reliability.

Material Specifications

Body/Bonnet: Ductile Iron/Stainless Steel
Disc & Stem: Stainless Steel
Piping: Bronze/Stainless Steel/Rubber Hose
Diaphragm: EPDM
Fasteners and Springs: Stainless Steel

Working Pressure Range

175PSI/235PSI
 10Bar/16Bar

Flange Standards

ANSI / BSEN / ISO / DIN

Temperature/Medium

0°C~100°C normal temperature water

Please Provide the Following Data When Ordering

Valve figure number/size/pressure grade/
 connecting end type/other optional accessories

* Note: In valve installation, it is strongly suggested that sufficient space should be left for easy maintenance in the future. A strainer shall be mounted in front of the valve to prevent foreign matters from blocking the valve.

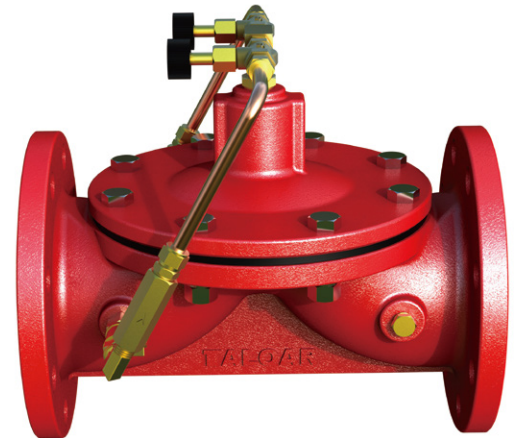

NC300

List of Accessories

- ① Strainer (Built-In)
- ② Ball Valve
- ③ Check Valve
- ④ Needle Type Regulating Valve
- ⑤ Ball Valve
- ⑥ Check Valve
- ⑦ Needle Type Regulating Valve

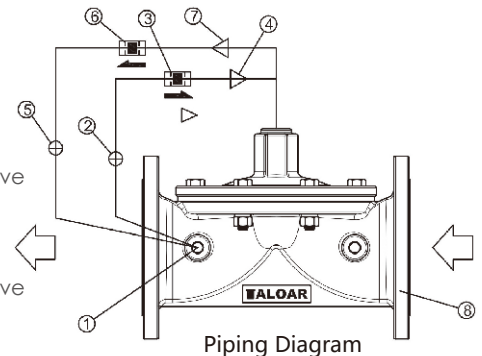

Typical Applications

● Deep Well Pump

In occasions where a deep well pump is required in design, the non-slam check valve should be installed. When the pump is shut down or sudden powered off, the non-slam check valve will close slowly to avoid the damaging water hammer caused by rapid back flow of fluid.

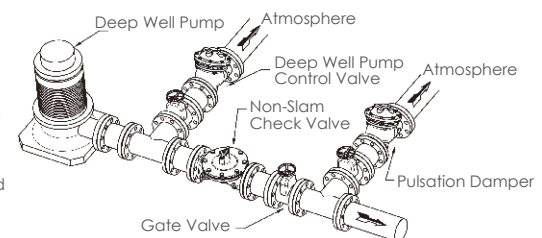

● Booster Pump

Install NC300 non-slam check valve at the outlet of booster pump can prevent fluid from entering the water storage tank when the pump is shut down. The pressure relief valve shown in the diagram can effectively prevent the impact occurring during pump shutdown.

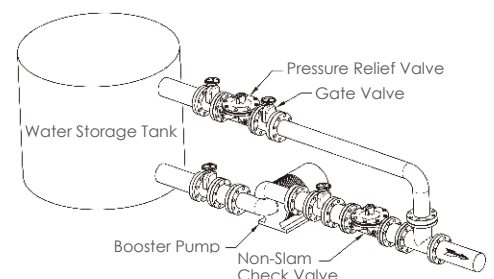

Product Features

- Sensitive and rapid action
- Small volume and light weight
- Easy regulation and maintenance
- Excellent and reliable sealing performance
- Built-in strainer, to prevent the guide piping system from being blocked
- Optional check feature

SL300 solenoid control valve mainly controls opening and closing of the valve by receiving the opening or closing signal through the solenoid valve. It consists of a basic valve and an electromagnetic switch. The electromagnetic switch controls the liquid in the air chamber to achieve the purpose of controlling the valve to open and to close.

The standard opening and closing speed control valve can independently control the opening and closing speeds of the valve to avoid the water hammer and vibration common in solenoid valves.

If the optional check feature is selected, when the back pressure is generated, the return fluid will enter the air chamber to close the valve to prevent the fluid from back flow.

Material Specifications

Body/Bonnet: Ductile Iron/Stainless Steel
Disc & Stem: Stainless Steel
Piping: Bronze/Stainless Steel/Rubber Hose
Diaphragm: EPDM
Fasteners and Springs: Stainless Steel

Working Pressure Range

175PSI/235PSI
 10Bar/16Bar

Flange Standards

ANSI / BSEN / ISO / DIN

Temperature/Medium

0°C~100°C normal temperature water

Solenoid Valve Parameters

Voltage Range: 110 V, 50-60 Hz, AC or 220 V, 50-60 Hz

State: NC (normally closed) or NO (normally open) (please specify the specific state while ordering)

Body Material: Brass/Stainless steel

Please Provide the Following Data When Ordering

Valve figure number/size/pressure grade/connecting end type/voltage range/NC or NO/other optional accessories

* Note: In valve installation, it is strongly suggested that sufficient space should be left for easy maintenance in the future. A strainer shall be mounted in front of the valve to prevent foreign matters from blocking the valve.

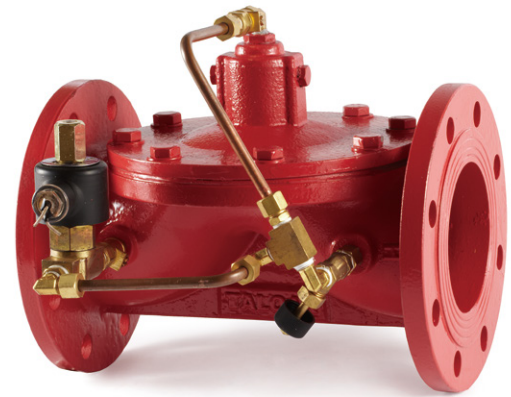

SL300

List of Accessories

- ① Strainer (Built-In)
- ② Ball Valve
- ③ Needle Type Regulating Valve
- ④ Ball Valve
- ⑤ Electromagnetic Switch
- ⑥ Ball Valve
- ⑦ Body

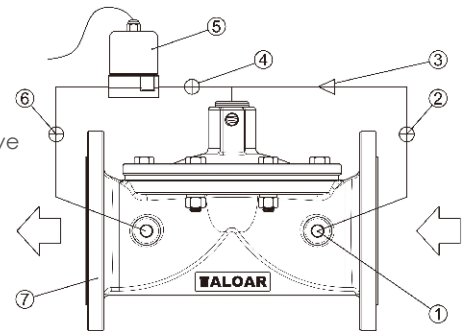

Piping Diagram

Typical Applications

SL300 solenoid control valve is applicable to many situations in the industry, such as mixing, cleaning, stirring and other occasions that require switching control.

The switching signal can direct control signal or the signal generated by the sensor to control the valve to open and to close. The solenoid control valve can be used to control water level. The sensor installed on the water storage tank generates the switching signal to control the opening and closing of solenoid control valve, so as to control water level.

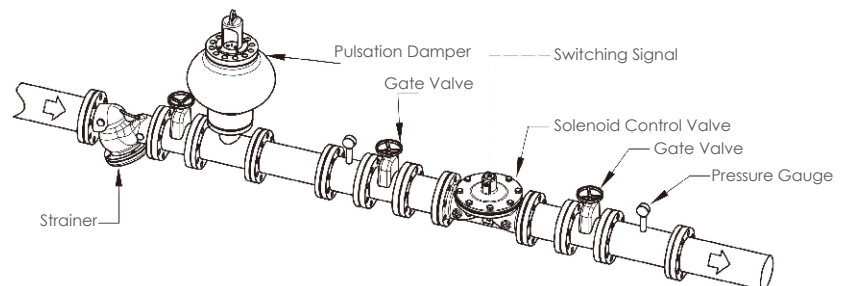

Product Features

- Precise differential pressure control
- Small volume and light weight
- Large flow
- Reliable full hydraulic control
- Tight and reliable sealing performance in closing
- Built-in strainer, to prevent the guide piping system from being blocked

DR300 lightweight pressure differential relief valve is a fully automatic hydraulic control valve, designed to maintain pressure differential between two pipelines, to avoid the pressure differential of pipelines exceeding the range the system can hold due to other valves operation or demand change. The valve will open when the pressure differential increases and will automatically close when the differential pressure decreases.

If the optional check feature is selected, back pressure is generated, the return fluid will enter the air chamber to close the valve to prevent the fluid from back flow.

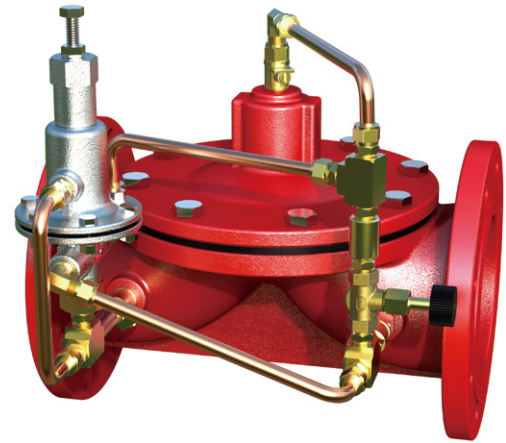

DR300

Material Specifications

Body/Bonnet: Ductile Iron/Stainless Steel
Disc & Stem: Stainless Steel
Piping: Bronze/Stainless Steel/Rubber Hose
Diaphragm: EPDM
Fasteners and Springs: Stainless Steel

Working Pressure Range

175PSI/235PSI
 10Bar/16Bar

Flange Standards

ANSI / BSEN / ISO / DIN

Temperature/Medium

0°C~100°C normal temperature water

Pressure Regulator Parameters

Pressure Regulating Range: 0.1~2.5 kgf/cm²,
 2~9 kgf/cm², 7~17 kgf/cm²

Pressure Regulator Material:
 Brass/Stainless Steel

Please Provide the Following Data When Ordering

Valve figure number/size/pressure grade/
 connecting end type/pressure regulating
 range/other optional accessories

* Note: In valve installation, it is strongly suggested that sufficient space should be left for easy maintenance in the future. A strainer shall be mounted in front of the valve to prevent foreign matters from blocking the valve.

List of Accessories

- ① Strainer
- ② Ball Valve
- ③ Needle Type Regulating Valve
- ④ Ball Valve
- ⑤ Differential Pressure Controller
- ⑥ Ball Valve
- ⑦ Body

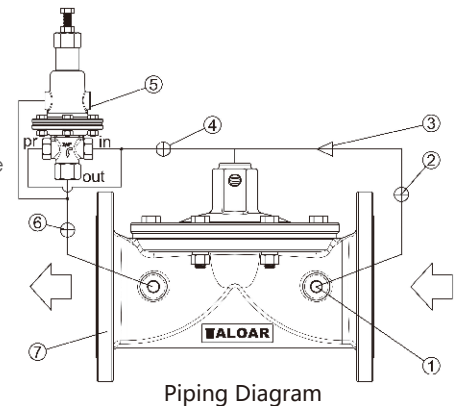

Piping Diagram

Typical Applications

The differential pressure relief valve can maintain pressure differential of the flow through the centrifugal pump. Disregard the upstream supply or downstream demand changes, the pressure differential can always be maintained within a certain range. The flow of the pump can be controlled by controlling the pressure differential between both ends of the centrifugal pump.

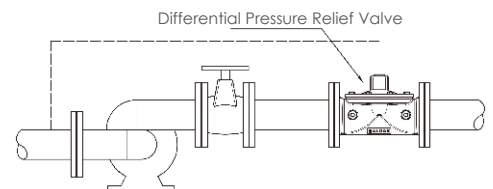

Installing DR300 differential pressure relief valve in the circulating water system, as shown in the diagram, can guarantee the pressure differential between the supply pipeline and the return pipeline, disregard the flow or supply pressure changes, the differential pressure between the two pipelines always remains constant.

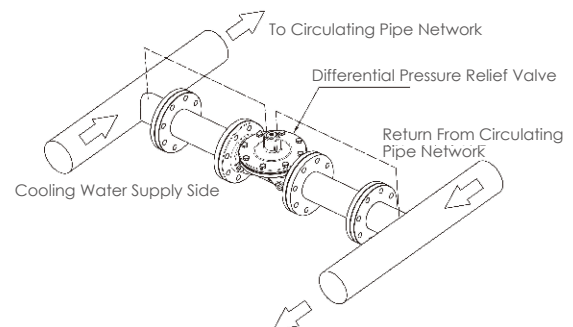

Product Features

- All stainless steel body and guide piping fittings
- Sensitive and precise pressure control
- Small volume and light weight
- Easy regulation and maintenance
- Excellent sealing performance
- Built-in strainer, to prevent the guide piping system from being blocked

PR300S lightweight pressure reducing valve can automatically reduce high pressure at the inlet to a stable low pressure at the outlet, regardless of changes in fluid velocity or inlet pressure, maintain outlet pressure within the preset range by a precise pressure regulator. When outlet pressure exceeds the set range of the pressure reducing valve, the basic valve body and the pressure regulator will automatically close to form a tight seal.

If the optional check feature is selected, back pressure is generated, and the return fluid will enter the air chamber to close the valve to prevent the fluid from back flow.



PR300S

Material Specifications

Body/Bonnet: Stainless Steel

Disc & Stem: Stainless Steel

Piping: Stainless Steel

Diaphragm: EPDM

Fasteners and Springs: Stainless Steel

Working Pressure Range

175PSI/235PSI/350PSI

10Bar/16Bar/25Bar

Flange Standards

ANSI / BSEN / ISO / DIN

Temperature/Medium

0°C~100°C normal temperature water

Pressure Regulator Parameters

Pressure Regulating Range: 0.1~5 kgf/cm²,
5~9 kgf/cm², 7~17 kgf/cm²

Pressure Regulator Material:
Stainless Steel

Please Provide the Following Data When Ordering

Valve figure number/size/pressure grade/
connecting end type/pressure regulating
range/other optional accessories

* Note: In valve installation, it is strongly suggested that sufficient space should be left for easy maintenance in the future. A strainer shall be mounted in front of the valve to prevent foreign matters from blocking the valve.

List of Accessories

- ① Strainer (Built-In)
- ② Ball Valve
- ③ Needle Type Regulating Valve
- ④ Ball Valve
- ⑤ Pressure Reducing Valve
- ⑥ Ball Valve
- ⑦ Body

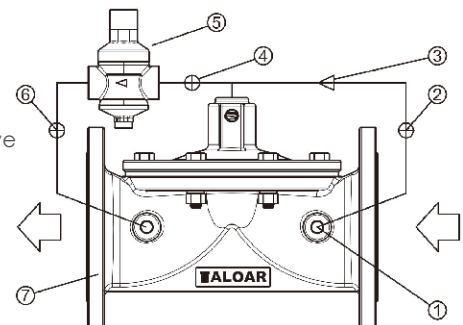

Piping Diagram

Typical Applications

If flow demand varies in a large range, multiple PR300S pressure reducing valves should be used in parallel. In case of large flow demand, two pressure reducing valves will work simultaneously. In case of small flow demand, the large-sized valve will automatically close, while the small-sized valve will continue to provide the required flow. When setting the pressure regulating range for the valves, the set pressure of the small-sized valve should be about 0.3 kgf/cm² higher than that of the large-sized valve.

If the pressure reduction range is large, multiple PR300S pressure reducing valves should be used in series for sectional pressure reduction.

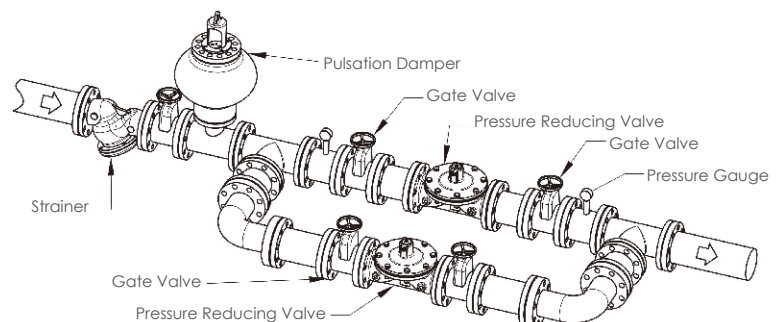

Product Features

- All stainless steel body and guide piping fittings
- Precise pressure control
- Small volume and light weight
- Fast opening, to guarantee pipeline pressure
- Non-slam design, to prevent fluid impact
- Built-in strainer, to prevent the guide piping system from being blocked

RS300S lightweight pressure relief valve/pressure holding/back pressure valve is a hydraulic control valve controlled by a pressure regulator. It maintains pressure in upstream pipelines and also can be used in pressure relief, pressure holding and back pressure situations. During operation, the valve senses inlet pressure of the valve by the pilot pressure regulator to control the valve to open or to close. When inlet pressure exceeds the set value, the valve will open quickly to maintain pressure in the pipelines. After pressure release, the valve will close gradually to prevent impact.



RS300S

Material Specifications

Body/Bonnet: Stainless Steel

Disc & Stem: Stainless Steel

Piping: Stainless Steel

Diaphragm: EPDM

Fasteners and Springs: Stainless Steel

Working Pressure Range

175PSI/235PSI/350PSI

10Bar/16Bar/25Bar

Flange Standards

ANSI / BSEN / ISO / DIN

Temperature/Medium

0°C~100°C normal temperature water

Pressure Regulator Parameters

Pressure Regulating Range: 0.1~5 kgf/cm²,
2~9 kgf/cm², 7~17 kgf/cm²

Pressure Regulator Material:

Stainless Steel

Please Provide the Following Data When Ordering

Valve figure number/size/pressure grade/
connecting end type/pressure regulating
range/other optional accessories

* Note: In valve installation, it is strongly suggested that sufficient space should be left for easy maintenance in the future. A strainer shall be mounted in front of the valve to prevent foreign matters from blocking the valve.

List of Accessories

- ① Strainer
- ② Ball Valve
- ③ Needle Type Regulating Valve
- ④ Needle Type Regulating Valve
- ⑤ Pressure Relief Valve
- ⑥ Ball Valve
- ⑦ Body

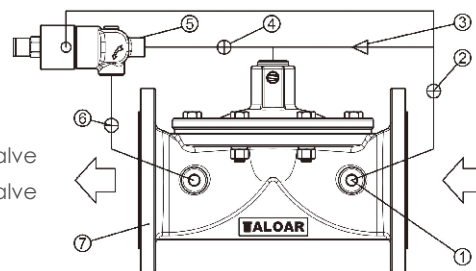

Piping Diagram

Typical Applications

● As a Pressure Relief Valve

To prevent high-pressure impact generated during pump shutdown, the quick opening and slow closing, the pressure relief valve can be used to release excess high pressure to protect the system.

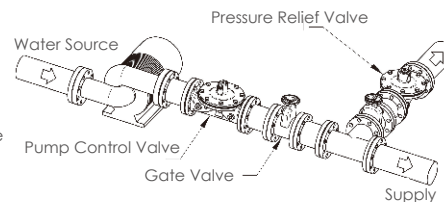

● As a Pressure Holding Valve

When the valve is installed between the high-pressure supply at upstream and large-flow demand at downstream, it can be used as a pressure holding valve to maintain high pressure at upstream, and to prevent pressure in the main pipe from dropping continuously due to excessive flow demand at downstream to maintain pressure in the main pipe.

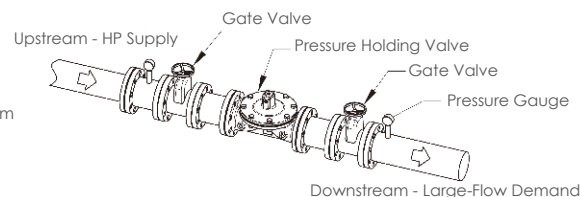

Product Features

- All stainless steel body and guide piping fittings
- Precise and repeatable water level control
- Small volume and light weight
- Reliable full hydraulic control
- Reliable tightness
- Large flow
- Built-in strainer, to prevent the guide piping system from being blocked

FM300S diaphragm float valve is a hydraulic controlled valve. It keeps the water level in the storage tank at a relatively stable level. The float control switch is installed in the water tank when the water level is high and is connected to the basic valve through the pipeline. When the water level rises and exceeds the maximum limited level, the float pilot valve will fully close and the basic valve automatically closed. When the water level drops to the lowest limited level, the float pilot valve will be fully open, the basic valve will automatically open for water supplement until the level in the water storage tank is controlled within the stable ideal range.

If the optional check feature is selected, when the back pressure is generated, the return fluid will enter the air chamber to close the valve to prevent the fluid from back flow.

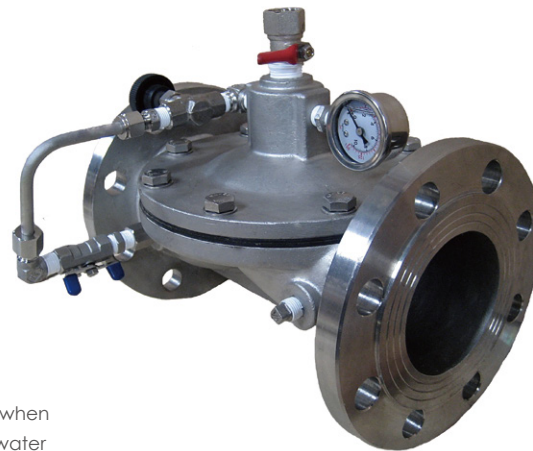

FM300S

Material Specifications

Body/Bonnet: Stainless Steel

Disc & Stem: Stainless Steel

Piping: Stainless Steel

Diaphragm: EPDM

Fasteners and Springs: Stainless Steel

Working Pressure Range

175PSI/235PSI/350PSI

10Bar/16Bar/25Bar

Flange Standards

ANSI / BSEN / ISO / DIN

Temperature/Medium

0°C~100°C normal temperature water

Float Switch Parameters

Controller: 1/2" Float Valve
(to be purchased separately)

Body Material: Brass/Stainless Steel

Please Provide the Following Data When Ordering

Valve figure number/size/pressure grade/ connecting end type/other optional accessories

* Note: In valve installation, it is strongly suggested that sufficient space should be left for easy maintenance in the future. A strainer shall be mounted in front of the valve to prevent foreign matters from blocking the valve.

List of Accessories

- ① Strainer (Built-In)
- ② Ball Valve
- ③ Needle Type Regulating Valve
- ④ Ball Valve
- ⑤ Body

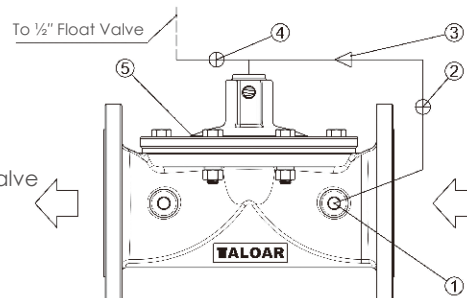

Piping Diagram

Typical Applications

Install the valve and float control switch as shown in the diagram. The float control switch should be installed on the relative static water surface at the outlet of the connected pipeline and positioned at the desired water level.

The outlet should be as far away from the float controller as possible (recommended: >5 m), otherwise, the level fluctuation generated by the water outlet may cause frequent valve opening and closing, to produce noise and thus shorten the service life of the valve.

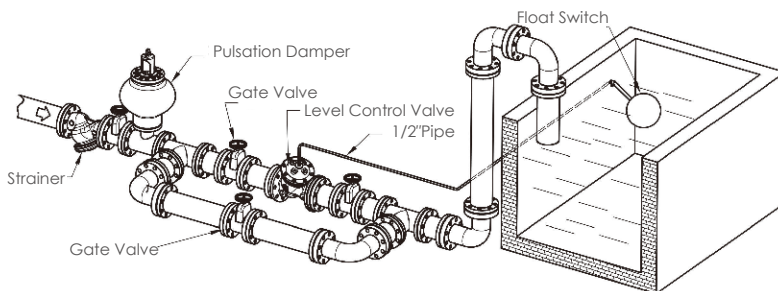

Product Features

- Safe partition and low head loss
- Light weight
- Reliable sealing performance
- Compact structure design, saving installation space
- Easy maintenance, and vertical or horizontal installation

500X backflow prevention device consists of a basic valve with two-stage non-return device and an external drainer, where both ends of the drainer's guide piping are connected to the inlet and outlet of the basic valve respectively. When inlet pressure is greater than the outlet pressure, the drainer will automatically close. When the outlet pressure is greater than inlet pressure, the drainer will automatically open to drain the medium in the middle chamber of the basic valve to form an air partition to ensure the water supply safety.



500X

Material Specifications

Body/Bonnet: Ductile Iron/Stainless Steel

Disc: Stainless Steel

Seat: Stainless Steel

Spring: Stainless Steel

Drainer: Stainless Steel

Seal Ring: NBR

Working Pressure Range

175PSI/235PSI/350PSI

10Bar/16Bar/25Bar

Flange Standards

ANSI / BSEN / DIN

Temperature/Medium

0°C~100°C normal temperature water

Opening Pressure/Local Head Loss

≤0.3 Bar

Please Provide the Following Data When Ordering

Valve figure number/size/pressure grade/connecting end type/other optional accessories

* Note: In valve installation, it is strongly suggested that sufficient space should be left for easy maintenance in the future. A strainer shall be mounted in front of the valve to prevent foreign matters from blocking the valve.

List of Accessories

- ① Body
- ② Front Seat
- ③ Valve Shaft
- ④ Front Disc
- ⑤ Main Spring
- ⑥ Rear Seat
- ⑦ Rear Disc
- ⑧ Guide Bush
- ⑨ Aux Spring
- ⑩ Drainer

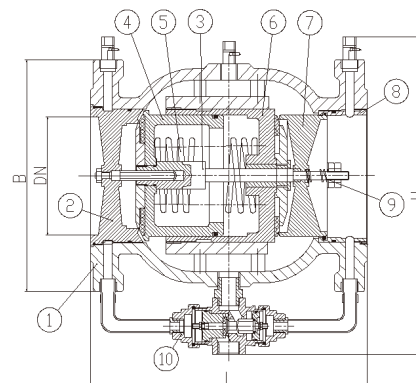

Overall Dimensions

Size (mm)	50	65	80	100	125	150	200	250	300
L (mm)	190	210	225	250	300	340	400	460	540
B (mm)	165	185	200	215	250	280	340	405	460
H (mm)	190	205	225	252	290	318	370	500	560

Installation and Maintenance

To facilitate installation and maintenance and ensure the normal use of the backflow prevention device, the control valve and the strainer should be installed before the backflow prevention device and the flexible connector, and the control valve should be installed after the backflow prevention device.

At the drain outlet of the backflow prevention device, a drain pipe should be installed about ≥100 mm above the water collecting well. No valve should be installed in the drain pipeline to block the flow of the medium. The drainage diameter of the water collecting well should ensure smooth drainage.

To facilitate routine inspection and maintenance, the low-resistance backflow prevention device should not be installed in the outdoor well. It is recommended to install the backflow prevention device indoor, with sufficient reserved space. Generally the spacing to the lower edge should be ≥300 mm for convenient installation and maintenance.

The low-resistance backflow prevention device can be installed horizontally or vertically and the flow direction of medium in pipelines should be in line with the direction indicated by the arrow marked on the basic valve body.

Before installation, the pipe network must be thoroughly cleaned. Besides, the strainer screen of the strainer must be cleaned regularly.

Product Features

- Built-in deflector, making the fluid more stable
- Start-up strainer screen protection design, preventing foreign bodies from entering the pump
- Diffusers with the same or different diameters at inlet and outlet readily available.
- Integrate strainer, elbow and the suction stabilizer, save space and cost
- Strainer screen with 63% opening ratio provides larger flow area than the traditional strainer



SD230

Material Specifications

Body/Bonnet: Ductile Iron

Start-Up Protection Strainer Screen: Stainless Steel (20-mesh)

O-Ring: EPDM

Working Pressure Range

175PSI/235PSI/350PSI

10Bar/16Bar/25Bar

Flange Standards

ANSI / BSEN / DIN

Temperature/Medium

0°C~100°C normal temperature water

(For any special applications and requirements, please clearly specify them before ordering)

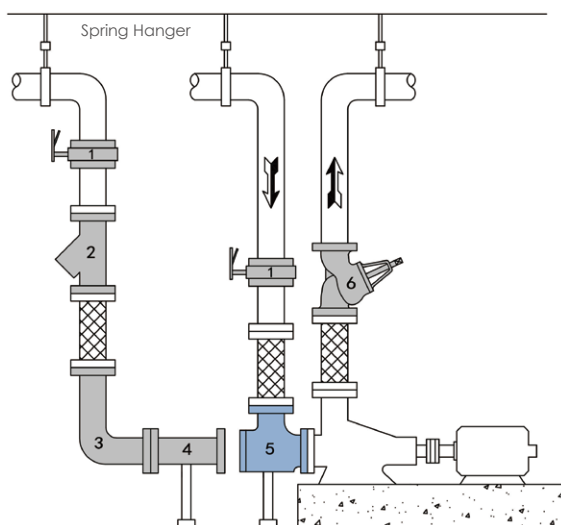

1. Butterfly Valve
2. Y-Type Strainer
3. Bend
4. Suction Stabilizer
5. Diffuser
6. Multi-Function Valve

Diffuser Pressure Drop Curve

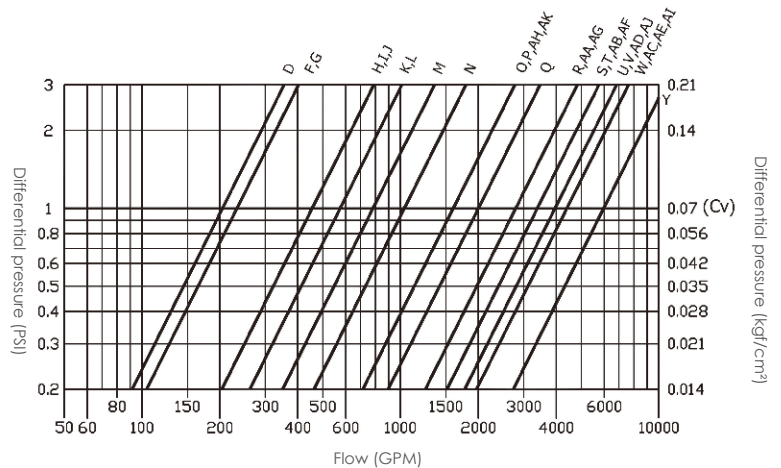

Specification Example

The contractor should install the diffuser at the designated position. 14" * 12" diffuser should be made of ductile iron with a deflector. The strainer should be made of stainless steel with a 20-mesh stainless steel start-up protection strainer screen. There should be a platform on the valve body for welding support.

>> Overall Dimensions

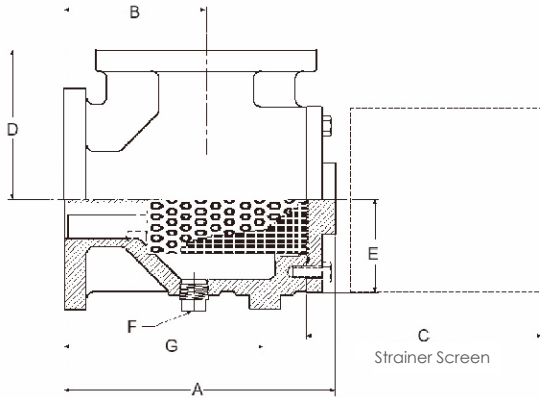

* Notes

1. All dimensions are in mm, and area of passage is in cm².
2. All dimensions, areas and weights in the table are approximate.
3. Once system test run is done, remove the start-up protection strainer screen.
4. The start-up protection strainer screen is a 20-mesh screen.
5. When the pressure differential between the inlet and outlet of the diffuser exceeds 0.3 kgf/cm², remove the waste in the diffuser.
6. In case of special requirements, please contact the factory for more details.

Code	Size (In)	Inlet (mm)	Outlet (mm)	Strainer Screen		Dimensions (mm)							Weight	
				Total Punching Area	Punching Dia	A	B	C	D	E	F	G	Lbs	kg
C	2x2	50	50	96	2	205	120	127	108	60	15	155	22	10
D	2.5x2.5	65	65	240	3.97	220	125	138	115	80	15	165	37	17
F	3x3	80	80	330	3.97	255	135	162	130	90	25	185	55	25
G	4x3	100	80	330	3.97	255	135	162	130	90	25	185	55	25
H	4x4	100	100	500	3.97	330	185	202	145	105	25	240	71	32
I	5x4	125	100	500	3.97	330	185	202	145	105	25	240	77	35
K	5x5	125	125	800	3.97	410	230	265	180	120	25	300	88	40
J	6x4	150	100	500	3.97	330	185	202	145	105	25	240	82	37
L	6x5	150	125	800	3.97	400	230	265	180	120	25	300	106	48
M	6x6	150	150	930	3.97	400	220	257	209	140	25	275	128	58
N	8x6	200	150	930	3.97	400	220	257	205	140	25	275	132	60
O	8x8	200	200	1600	3.97	501	280	350	240	170	25	370	203	92
AK	10X6	250	150	1600	3.97	501	280	350	240	170	25	370	187	85
P	10x8	250	200	1600	3.97	501	280	350	240	170	25	370	209	95
Q	10x10	250	250	2500	3.97	615	325	465	280	190	25	425	282	128
AH	12X8	300	200	2500	3.97	625	325	465	280	190	25	425	287	130
R	12x10	300	250	2500	3.97	615	325	465	280	190	25	425	353	160
S	12x12	300	300	3350	3.97	680	380	535	305	240	25	485	472	214
AG	14X10	350	250	3240	3.97	680	380	535	305	240	25	485	498	226
T	14x12	350	300	3350	3.97	682	380	535	305	240	25	485	507	230
U	14x14	350	350	4880	3.97	790	420	625	356	280	25	550	562	255
AA	16x10	400	250	3490	3.97	700	380	543	320	260	25	480	562	255
AB	16x12	400	300	3490	3.97	700	380	543	320	260	25	480	578	262
V	16x14	400	350	4880	3.97	783	420	625	356	280	25	550	584	265
W	16x16	400	400	5290	3.97	790	450	615	400	320	25	550	816	370
AF	18 X12	450	300	3980	3.97	769	430	615	320	240	25	480	617	280
AJ	18X14	450	350	4880	3.97	783	420	625	356	280	25	550	662	300
AC	18X16	450	400	5630	3.97	825	450	656	400	320	25	580	860	390
X	18 x18	450	450	7960	3.97	975	540	805	430	350	25	680	1116	506
AD	20X14	500	350	7000	3.97	1020	600	810	500	360	25	750	1279	580
AE	20X16	500	400	7000	3.97	1020	600	810	500	360	25	750	1286	583
Y	20x20	500	500	9730	3.97	1068	650	855	500	400	25	750	1290	585
AI	22X16	550	400	7260	3.97	1050	600	840	500	360	25	750	1312	595

Product Features

- Unique diaphragm design
- Unique check valve structure design
- Lug type protective cover
- Integrated body
- Air chamber of various volumes available
- Compact, light weight

The pulsation damper is a special pressure storage device used for pressurized liquid. It is well known that liquid cannot be compressed. However we can solve this problem by compressing the gas (see Fig. 1 for details).

PD608 pulsation damper has a detachable air bag with joints installed in its pressure shell. Inert gas (nitrogen) with pressure P_0 is filled into the air bag through the inlet valve until the air bag expands and fills the entire internal space of the pulsation damper with volume V_0 .

When the circulating pressure P_1 is greater than the preset pressure P_0 of the gas, the hydraulic valve at the bottom will open, and the volume of the air bag will be compressed to V_1 because of the effect of external circulating pressure.

If the liquid pressure increases to P_2 , the gas volume will decrease to V_2 , and pressure will increase to balance liquid pressure. That is, the air chamber inside the pulsation damper is compressed, with the volume change $\Delta V = V_1 - V_2$. That way, the energy stored in the pulsation damper can be used.



PD608

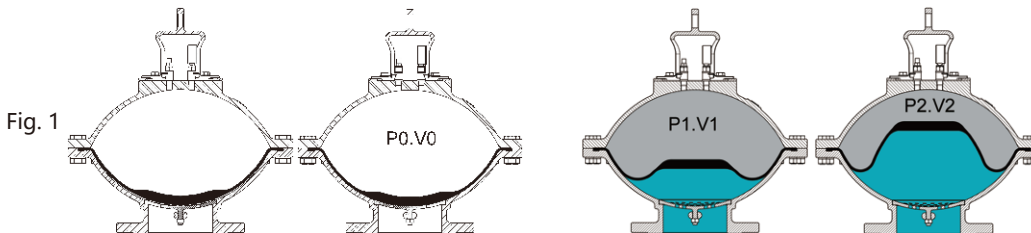

Material Specifications

- ① Protective Cover (Ductile Iron)
- ② Pressure Gauge
- ③ Inflatable Nozzle (Stainless Steel)
- ④ Top Cover (Carbon Steel/Stainless Steel)
- ⑤ Shell (Stainless Steel)
- ⑥ Air Chamber (EPDM/VITON)

Working Pressure

Max. Working Pressure: 25 bar;
Max. Allowed Pressure: 55 bar

Volume

0.7L, 3L, 6L, 17L, 30L, 50L

Flange Standards

ANSI / BSEN / ISO / DIN

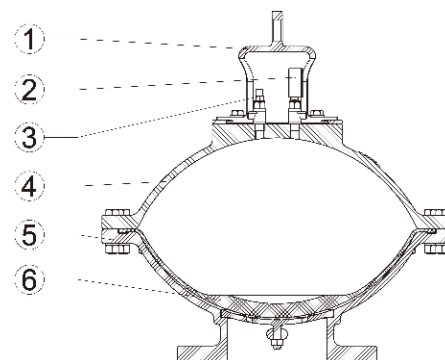

Note: Water hammer eliminators with different chamber capacities can be calculated based on the actual pipe length, flow rate, head and other parameters provided by the user on site for special use environments.

>> Main Applications

● As a Backpressure Impact Damper

If there is a sudden power off for the pump while transporting the liquid to a high spot, the liquid in the pipeline will return and accelerate in the pipeline. Water hammer with great destructive power will be formed at the check valve that is installed at the outlet of the pump. If the pipeline is long, the water hammer may cause the pipeline to burst. The longer the pipeline, the longer the fluid accelerate, the bigger the impact. TALOAR pulsation damper can effectively absorb such water hammer. Besides, TALOAR pulsation damper is designed with a unique check valve structure with "fast-in and slow-out" feature, can effectively absorb water hammer instantly. It takes relatively long time to release excess pressure, ensuring stable pressure in the pipeline system.

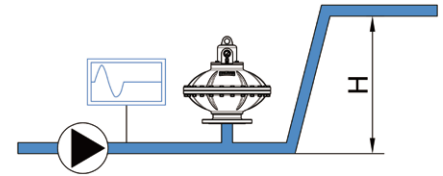

● As a Supply-End Shock Absorber

The cyclic piston movement within the circulating pump will naturally generate water hammer and hydraulic impacts. During the discharge stroke of the pump, excess liquid will enter the pulsation damper to absorb excess pressure. During the piston return, the liquid absorbed in the pulsation damper will enter the system to supplement the pressure drop caused by the piston return of the pump to finally stabilize system pressure.

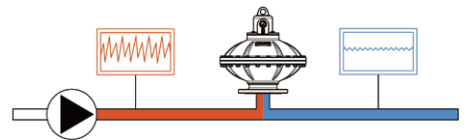

● As a Suction-End Shock Absorber

If there is no sufficient water supply, the pump efficiency will highly affected. Pitting is related to the fluid velocity, acceleration, and friction. If the supply at pump suction is insufficient, vacuum will form at the supply under the suction of the pump, resulting in "pitting".

Install TALOAR pulsation damper at the pump suction. This will act a buffer pool: If the suction of the pump is insufficient, the liquid stored in the pulsation damper will be supplied to the system to ensure the pump suction is sufficient. If the system supply is too large, excess liquid will enter the pulsation damper to ensure pump suction is stable, thus greatly improving the service life of the pump.



● As a Hydraulic Impact Damper

All liquid flow has kinetic energy. When the fluid suddenly stopped, its kinetic energy will convert into pressure and this very dangerous. Such "water hammer phenomenon" usually occurs in pipeline systems with quick-closing valves. The destructive power generated by "water hammer phenomenon" is strong enough to damage devices like pipelines, valves, and pumps.

There are many reasons for "water hammer phenomenon", such as quick-closing valves, back pressure impact, pump start-up or shutdown and sudden loss of power in the system (such as power failure).

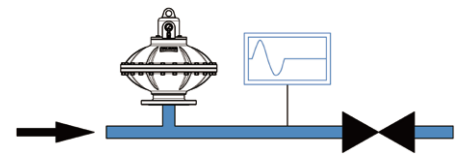

● Energy Storage

If the system experiences sudden power off or pump failure, TALOAR pulsation damper can maintain pressure within the system for a short time to ensure that other moving and working parts are still lubricated and cooled, so as to protect the equipment.

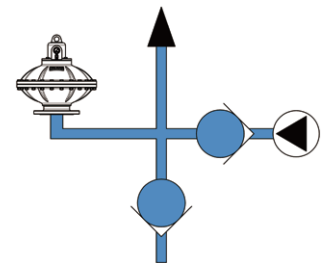

● Thermal Expansion Absorption

When liquid flows in a closed system, the liquid temperature will rise due to friction or other reasons, the resulting liquid expansion will cause the system pressure to increase. If the pressure exceeds safety pressure limit of the system, it will cause the pipeline to burst, valve failure, damage to precision instruments on the pipelines. Besides, in case of system leakage, the liquid in the pipelines may cause permanent damage to personnel and the surrounding environment. Use TALOAR pulsation damper will absorb the excess pressure caused by the thermal expansion of the liquid to ensure the safe operation of the system.

● Isolation Device

If the pressure parameters of the system are extremely important for safety operation of the system, the instruments measuring such parameters are not allowed to contact with the fluid in the system, Now TALOAR pulsation damper can help solve this problem. In this case, the diaphragm of TALOAR pulsation damper performs an isolation function.

>> Overall Dimensions

*** Note:**

The absorption effect of the pulsation damper on water hammer is not based on diameter, but on the volume, because the volume of the pulsation damper with the same diameter can vary greatly. For example, for a 4" pulsation damper, its volume is 10 L or 100 L. When it is applied in the same system, the pulsation damper with the volume of 100 L has better absorption effect on water hammer.

TALOAR 2" pulsation damper can hold the volume of 10 L or 100 L. If wrong pulsation damper is selected, the same 2" pulsation damper can perform not even 1/4 absorbing effect in compare with 2" pulsation damper with the corrected volume.



Size(mm)	In	H(mm)	D(mm)	Volume(ml)
50	2	240	180	700
65	2 1/2	355	300	3000
80	3	355	300	3000
100	4	395	360	6000
125	5	395	360	6000
150	6	500	500	17000
200	8	565	570	30000
250	10	565	570	30000
300	12	620	650	50000

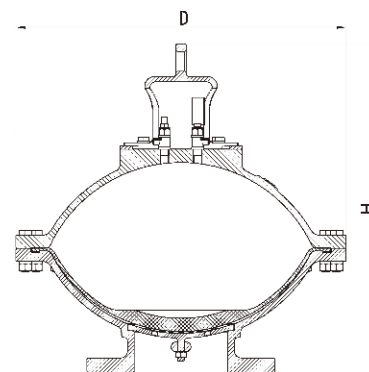

>> Characteristics of Air Bag Material

Polymer	ISO	Applicable TEMP (°C)	Applicable Media
Standard Nitrile Butadiene Rubber	NBR	-20+85	Mineral oil, vegetable oil, silicone oil, lubricating oil, water for industrial use, ethylene glycol, nonflammable liquid (HFA-HFB-HFC), aliphatic, carbon hydride, butane, diesel oil, fuel oil, etc.
Low-Temp Resistant Nitrile Butadiene Rubber	NBR	-40+70	Those media applicable to standard nitrile butadiene rubber, and various Freons (the content of acrylonitrile in low-temperature resistant nitrile butadiene rubber is less than that in standard nitrile butadiene rubber, so the low-temperature resistant nitrile butadiene rubber is more suitable for use in low-temperature environment, but its chemical resistance is poor)
Nitrile For Hydride	NBR	-10+90	Regular premium aromatic gasoline (and those media applicable to standard nitrile butadiene rubber)
Hydrogenated Nitrile	HNBR	-50+130	Those media applicable to standard nitrile butadiene rubber (but with better effect in both high-temperature and low-temperature environments)
Used In The Food Industry	NBR	-20+85	Food (specify when ordering)
Butyl	IIR	-20+90	Phosphate ester, hot water, ammonia, some Freons (22-31-502), alkaline soda, ethylene glycol brake oil, some acid alcohol, ketone, ester, skyrol7000, etc.
Ethylene Propylene	EPDM	-20+90	Brake oil, hot water, leachate, detergent, alkaline water (HFC), many acids and alkalis, saline alkali solution, skydrol500, etc.
Chloroprene	CR	-20+85	Freons (12-21-22-113-114-115), aqueous solution, ammonia, carbon dioxide, mineral oil, paraffin oil, silicone oil
Epichlorohydrin	ECO	-30+100	Leaded gasoline, mineral oil

Product Features

- Sensitive and precise reaction
- All stainless-steel body and bolted bonnet
- Reliable sealing performance

RS1050 pressure relief valve, a diaphragm driven valve, when the pipeline pressure reaches its preset value, the valve will automatically open. Under normal working condition, the valve is compressed by the compression spring and stays in the closed state. The effective compression area of the valve is much larger than the seat, so the set pressure is precise, and the valve is very sensitive to inlet pressure.



RS1050

Size

1/2" ~ 2" (DN15mm-DN50mm)

Type

Diaphragm Driven Type

End

BSPT/NPT Threaded End

Material

SS304 or SS316 Stainless Steel

Temperature/Medium

0°C~100°C Water or Air

Working Pressure Range

16Bar / 235PSI

Inlet Pressure Regulating Range

0 – 6Bar, 3Bar – 12Bar, 10Bar – 16Bar

Please Provide the Following Data When Ordering

Valve figure number/size/
working pressure/pressure regulating range

* Note: In valve installation, it is strongly suggested that sufficient space should be left for easy maintenance in the future. A strainer shall be mounted in front of the valve to prevent foreign matters from blocking the valve.

Overall Dimensions

Size mm	15	20	25	32	40	50
L	78	88	88	122	122	160
H	125	140	140	195	195	220

List of Accessories And Their Materials

- | | |
|-----------------|-----------------------|
| ① Knob | ABS + Stainless Steel |
| ② Nut | Stainless Steel |
| ③ Cap | Stainless Steel |
| ④ Spring | Stainless Steel |
| ⑤ Nut | Stainless Steel |
| ⑥ Spring Washer | Stainless Steel |
| ⑦ Bolt | Stainless Steel |
| ⑧ Nut | Stainless Steel |
| ⑨ Spring Washer | Stainless Steel |
| ⑩ Diaphragm | EPDM |
| ⑪ Disc & Stem | Stainless Steel |
| ⑫ Gasket | EPDM |
| ⑬ Bonnet | Stainless Steel |
| ⑭ O-Ring | EPDM |
| ⑮ Bottom Cap | Stainless Steel |
| ⑯ O-Ring | EPDM |
| ⑰ Body | Stainless Steel |

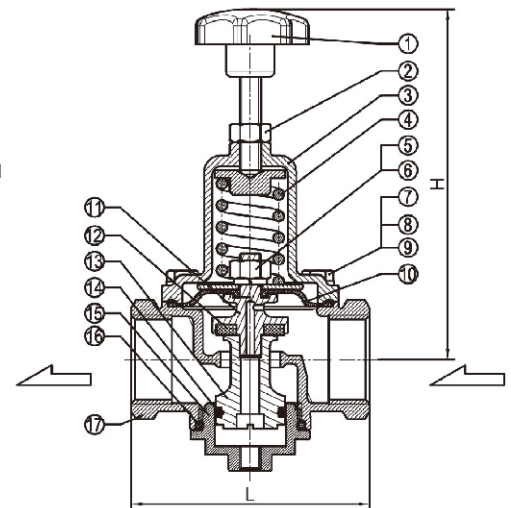

Pressure Gauges

Housing: SS (Stainless Steel)
Male Thread End: Brass/Stainless Steel
End Size: 1/8", 1/4", 1/2" BSPT/NPT
Dial Dia: 40 mm, 60 mm
Pressure Range: 0-10 Bar/cm², 0-16 Bar/cm², 0-25 Bar/cm²
Temperature Range: -10°C-180°C



FIG. PG50

Pressure Reducing Pilots

Body/Bonnet: Bronze/Stainless Steel
Disc: Bronze
Spring: Stainless Steel
Seal Ring: NBR
End Size: 1/2" BSPT
Temperature Range: -10°C-100°C
Pressure Regulating Range: 0.1-5 Bar/cm², 5-9 Bar/cm², 7-17 Bar/cm²



FIG. PD152

Pressure Relief Pilots

Body/Bonnet: Bronze/Stainless Steel
Disc: Bronze
Spring: Stainless Steel
Seal Ring: NBR
End Size: 1/2" BSPT (90° elbow with male and female threads)
Temperature Range: -10°C-100°C
Pressure Regulating Range: 0.1-5 Bar/cm², 2-9 Bar/cm², 7-17 Bar/cm²



FIG. PD162

Needle Valves

Body Material: Bronze
Stem: Brass
Nut: Brass
Seal Ring: NBR
End Size: 1/4" BSPT



FIG. NE32

Linear Ball valves

Body Material: Brass
Ball Core: Nickel Plated Copper
End Size: 1/4" BSPT
End Type: Female Threads x Male Threads



FIG. B35

Pressure Reducing Valves

Body/Bonnet: Brass
Disc: Brass
Spring: Stainless Steel
Diaphragm: NBR
Seal: NBR
End Type: BSPT Threads
Medium: Water
Max. Inlet Pressure: 16 Bar
Outlet Pressure: 1 Bar-6 Bar
Factory Pressure Setting: 3 Bar
Max. Operating Temp: 80°C
Pressure Gauge End: 1/4" BSPT



FIG. PD101

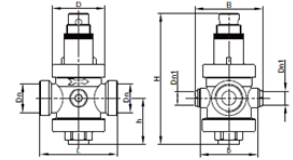

Size	Dn1	L	D	H	h	B	b
1/2"	1/4"	77	Ø50	125	45	65	55
3/4"	1/4"	77	Ø50	125	45	65	55
1"	1/4"	90	Ø64	150	61	75	65
1-1/4"	1/4"	125	Ø71	210	71	93	84.5
1-1/2"	1/4"	125	Ø71	210	71	93	84.5
2"	1/4"	125	Ø71	245	81	112	103

Solenoid Control Valves

Body/Bonnet: Bronze/Stainless Steel
Valve Shaft: Stainless Steel
Piston: Stainless Steel
Spring: Stainless Steel
Seal Ring: NBR
End Size: 1/2"- 2" BSPT
Temperature Range: -5°C-180°C
Medium: Water, Oil, Gas
Voltage: 220 V
Ex-Work Status: Normally Close/Normally Open



FIG. SL25

Check Valves

Body : Stainless Steel
Disc: Stainless Steel
End Size: 1/4" BSPT



FIG. C15

Strainers

Body : Brass
Strainer Screen: Stainless Steel
End Size: 1/4" BSPT



FIG. Y29

Test Fittings

Material: Brass
End Size: 1/4" BSPT
End Type: Male Threads
Seal: NBR

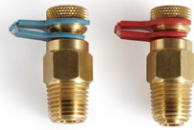

FIG. 1125

Extension Pipe Fittings

Material: Stainless Steel
End Size: 1/4" BSPT
Length: 50 mm
End Type: Male Threads x Male Threads



FIG. 1126

Tee Fittings

Material: Brass
End Size: 1/4" BSPT
End Type: Male Threads x Ferrule x Ferrule

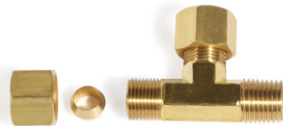

FIG. 1130

Tee Fittings

Material: Brass
End Size: 1/4" BSPT
End Type: Male Threads x Female Threads x Female Threads

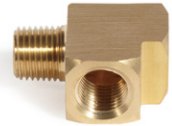

FIG. 1131

Elbow Fittings

Material: Brass
End Size: 1/4" BSPT
End Type: Male Threads x Ferrule



FIG. 1132

Adapter Fittings

Material: Brass
End Size: 1/4" BSPT
End Type: Dual Male Threads



FIG. 1134

Bushing Fittings

Material: Brass
End Size: 1/2" x 1/4" BSPT
End Type: Female Threads x Male Threads



FIG. 1135

Plug Fittings

Material: Brass
End Size: 1/4" BSPT
End Type: Male Threads



FIG. 1136

Diaphragms

Material: NBR/EPDM
End Size: 2" - 20"



FIG. D160

Float Switches

Body: Brass
Screw: Stainless Steel
Float Ball: Stainless Steel
Float Dia: 100 mm (other sizes can be customized)
Screw Length: 190 mm (other sizes can be customized)
End Size: 1/2" - 2" BSPT/NPT



FIG. FW170

Conversion Tables

Size	In	1/8	1/4	3/8	1/2	3/4	1	1 1/4	1 1/2	2	2 1/2	3	4	5	6	8	10	12	14	16
	DN	4	6	10	15	20	25	32	40	50	65	80	100	125	150	200	250	300	350	400
	In	18	20	24	26	28	30	32	34	36	42	48	54	60	64	72	80	84	88	96
	DN	450	500	600	650	700	750	800	850	900	1050	1200	1350	1500	1600	1800	2000	2100	2200	2400
Pressure	PSI	Pounds Per Sq.In.							0.069				Bar				Bar			
	PSI	Pounds Per Sq.In.							6.89				Kilopascals				Kpa			
	PSI	Pounds Per Sq.In.							0.07				Kilogram Per Sq.Centimeter				Kg/Cm ²			
	Lb./Ft. ²	Pounds Per Sq.Ft.							4.88				Kilogram Per Sq.Meter				Kg/m ²			
	Kpa	Kilopascals							0.145				Pounds Per Sq.In.				PSI			
	Kg/Cm ²	Kilogram Per Sq.Centimeter							14.22				Pounds Per Sq.In.				PSI			
	Bar	Pounds Per Sq.In.							0.069				Bar				Bar			
Length	In	Inches							2.54				Centimeters				Cm			
	Ft	Feet							30.48				Centimeters				Cm			
	mm	Millimeters							0.03937				Inches				In			
	Cm	Centimeters							0.3937				Inches				In			
	m	Meters							3.2808				Feet				Ft			
Mass	Oz	Ounces							28.35				Grams				G			
	Lb	Pound							0.4536				Kilograms				Kg			
	G	Grams							0.03527				Ounces				Oz			
	Kg	Kilograms							2.205				Pound				Lb			
Temperature	°F	Fahrenheit							$(°F-32) * 5/9$				Celsius				°C			
	°C	Celsius							$°C * 9/5 + 32$				Fahrenheit				°F			
Area	In ²	Square Inches							6.45				Square Centimeters				Cm ²			
	Ft ²	Square Feet							0.0929				Square Meters				m ²			
	Cm ²	Square Centimeters							0.155				Square Inches				In ²			
Volume	Fl.Oz	Fluid Ounces							29.5625				Milliliters				ml			
	Qt	Quart							0.946				Liters				L			
	Gal	Gallons							3.785				Liters				L			
	Ft ³	Cubic Feet							0.0283				Cubic Meters				M ³			
	ml	Milliliters							0.0338				Fluid Ounces				Fl.Oz			
	L	Liters							1.0571				Quart				Qts			
	L	Liters							0.2642				Gallons				Gal			
	M ³	Cubic Meters							35.34				Cubic Feet				Ft ³			
In ³	Cubic Inches							$5.787 * 10^{-4}$				Cubic Feet				Ft ³				

Installation (Please Read the Following Precautions Before Installation)

1. Before installing the valves, please check that the media actually used are consistent with the media applicable to the valves you purchased.
2. Before installing the valves, please clean the pipelines to ensure that there is no debris, impurities, sand and other foreign bodies in the pipelines.
3. It is recommended to install strainers at the inlets of the valves to avoid foreign body blockage affecting normal valve functions.
4. It is recommended to install on-off valves (gate valves or butterfly valves) at the inlets and outlets of the valves to facilitate future inspection and maintenance.
5. The valves should be installed in the direction shown by the arrow on the valve shell (the direction indicated by the arrow should be consistent with the flow direction).
6. The valves can be installed horizontally or vertically, be noted that sufficient space should be reserved around the valves for future commissioning, maintenance and disassembly.
7. When installing the valve, please pay special attention to the piping systems. In case of any damage to the piping system, the valves will fail to work normally.
8. The ball valves and needle valves in the piping systems should be in opened position.
9. The accessories can be replaced in the pipelines, without the need for removing the entire valves from the pipelines.



Commissioning Method of Pressure Relief Valves:

(Assume that the pressure relief starts when the system inlet pressure reaches 8.3 kgf/cm²)

1. Close the gate valve (or other on-off valve) before the pressure relief valve.
2. Open the black knob cap of the pressure relief pilot valve, adjust the pressure relief pilot valve
 - ⑤ clockwise to compress the spring inside the pressure relief pilot valve as much as possible.
3. Turn clockwise to close the needle valve ③, and then open it for one turn counterclockwise.

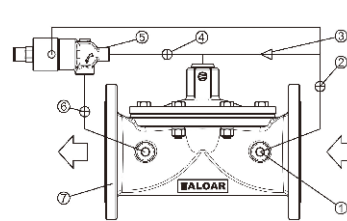

FIG. 300

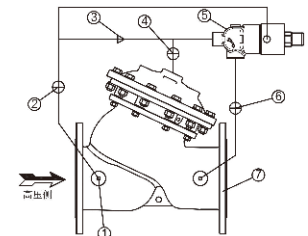

FIG. 500

Commissioning Method of Pressure Reducing Valves:

(Assume that the primary side pressure is 6 kgf/cm², and the secondary side pressure is set to 3 kgf/cm²)

1. Close the gate valves (or other on-off valves) before and after the pressure reducing valve.
2. Open the black knob cap of the pressure reducing pilot valve ⑤, and regulate counterclockwise to the loosest state (at this moment, the pressure gauge reading is zero).
3. Close the ball valve ⑥, as shown below.



Ball Valve Opened



Ball Valve Closed

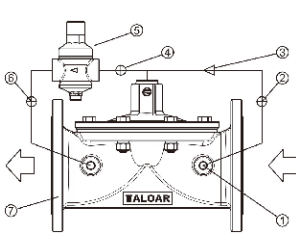

FIG. 300

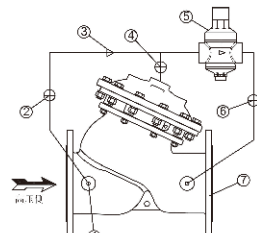

FIG. 500

4. Confirm that ②, ③ and ④ are all opened except that ball valve ⑥ is closed.
5. Open the primary side gate valve (at this moment, the pressure gauge reading remains zero).
6. Gently lock the pressure reducing pilot valve ⑤ clockwise, having the pressure gauge reading slowly increased to 3 kgf/cm². After the required pressure is obtained, lock the black knob cap.
7. Open the ball valve ⑥ and the secondary side gate valve to complete the pressure regulation for pressure reducing valve, after which water test can be started.

4. Slowly open the gate valve before the pressure relief valve to increase the input pressure at the inlet of the pressure relief valve to 8.3 kgf/cm² (i.e. pressure required by the system).
5. Adjust counterclockwise to unscrew the pressure relief pilot valve ⑤ until the pressure relief valve starts to drain (at this moment, sound of draining water can be heard).
6. Lock the black knob cap to complete the pressure regulation.
7. If it is necessary to increase the amount of water drained by the pressure relief valve, slowly turn needle valve ③ clockwise for fine adjustment.
8. After the above commissioning is completed, it is necessary to test the closing performance of the pressure relief valve: Slowly reduce inlet pressure to 8.2-8.1 kg/cm² to slowly close the pressure relief valve; to shorten the closing duration of the pressure relief valve, finely and slowly turn the needle valve ③ counterclockwise.
9. After the opening and closing of the pressure relief valve under the pressure drive both meet the requirements, it can be confirmed that the regulation for pressure relief valve is completed.





TALOAR®

Taloar Changzhou

Building 22, No. 666 Dailuo Road,
Yaoguan Town, Economic Development
Zone, Changzhou 213000
Tel.: +86 519 89665598
www.taloarvalve.com

* For any data errors or questions, contact the manufacturer.
* TALOAR reserves the right to change drawings, content, modifying or data updating herein without further notice.

